



clausius

Catalogue 2026

**Ground source heat pumps
NEW DOMESTIC AND HIGH POWER RANGES
WITH PROPANE**



clausius



clausius propane

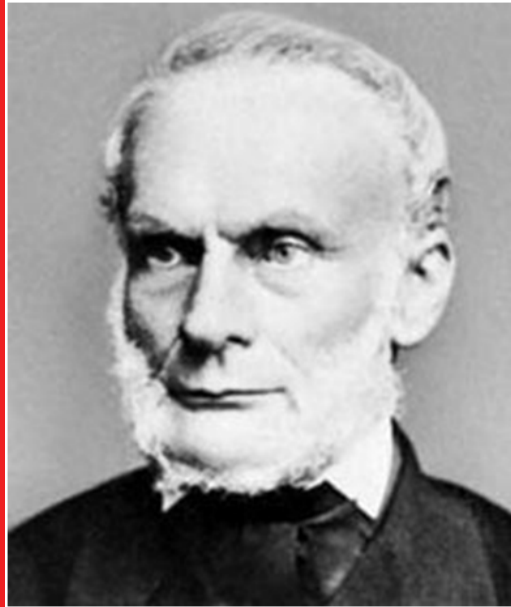

Rudolf CLAUSIUS (1822-1888)

German physicist who enunciated the 2nd Law of Thermodynamics applied to Heat Pumps and Refrigeration Systems. He is considered to be one of the first ecologists, soon in 1885 predicted, "***...the future of humanity depends on being able to feed our industries and machines with the only contest of renewable energy...***"

CLAUSIUS

CLAUSIUS is a new generation of ground source heat pumps that emerged after many years of serious and rigorous research at the University of Vigo.

At CLAUSIUS we design and develop only ground source heat pumps, which has allowed us to achieve a high degree of especialisation in this type of equipment. In these years we have managed to make CLAUSIUS a synonym of continuous innovation and incorporation of the latest technology in ground source heat pumps. We work every day with the sole objective of developing the most reliable and efficient ground source heat pumps on the market.

At CLAUSIUS the reliability of our heat pumps has become our obsession, with an awareness that it is only possible for us to deliver this reliability by using the best available components and testing our heat pumps one by one ourselves. All our heat pumps are fully tested in our laboratory before being shipped to any customer. We believe that only by testing each heat pump one by one it is possible for us to guarantee its reliability once installed.

At CLAUSIUS we control the brain... another important lesson learned through many years of experience is that the control system in a heat pump is what really makes the difference, that is why we develop and improve the control software of our heat pumps day by day, considering the opinions and requirements of our customers.

At CLAUSIUS we do not care if they follow us... it means that we are ahead...

Universida_{de}Vigo

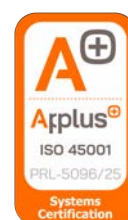

CLAUSIUS

- 
- 2014** **CLAUSIUS** was born as a SPIN-OFF company at the University of Vigo based on the research group's experience of more than 20 years in refrigeration systems and specifically in ground source heat pumps since 2005.
- 2015** **CLAUSIUS** develops and markets its range of domestic ground source heat pumps, Classic and Elite models throughout Europe.
- 2016** **CLAUSIUS** develops its range of high power ground source heat pumps, and develops its own internet connection system for heat pumps.
- 2017** **CLAUSIUS** manufactures and markets its range of high power ground source heat pumps, Strong and Strong Double models and develops its own cascade control system.
- 2018** **CLAUSIUS** manufactures the Classic model of the domestic range by ourselves and develops its exclusive high temperature heat pumps.
- 2019** **CLAUSIUS** manufactures and markets its range of high temperature heat pumps, HT models throughout Europe.
- 2020** **CLAUSIUS** develops and markets its own aerothermal system with its unique defrosting system and its own control for geothermal-aerothermal hybrid systems.
- 2021** **CLAUSIUS** manufactures the Elite model in the domestic range completing the manufacturing of all models of all our ranges of heat pumps by ourselves.
- 2022** **CLAUSIUS** develops and markets the control system for connecting and managing its heat pumps integrated with photovoltaic systems.
- 2023** **CLAUSIUS** develops its new range of propane heat pumps for domestic use and markets new internet connection system for all its heat pump models.
- 2024** **CLAUSIUS** begins production of its new range of domestic propane heat pumps, Classic P and Elite P models and develops its new range of high power heat pumps with propane, Strong P and Double Strong P.
- 2025** **CLAUSIUS** presents at the ISH trade fair in Frankfurt (Germany) and launches in the European market its new range of high power heat pumps (from 35 to 190 kW) with propane as a refrigerant.

INDEX

| | |
|---|-----------|
| Domestic range with R410A, CLASSIC & ELITE. | 7 |
| CLAUSIUS Technology. | 8 |
| CLASSIC Configuration. | 10 |
| CLASSIC Components. | 11 |
| ELITE Configuration. | 12 |
| ELITE Components. | 13 |
| Technical specifications. | 14 |
| CLASSIC & ELITE optional equipment | 15 |
| Customised configuration | 18 |
| High power range with R410A, STRONG & STRONG DOUBLE | 19 |
| CLAUSIUS STRONG & STRONG DOUBLE technology. | 20 |
| STRONG 7-50 & 12-75 configuration | 22 |
| STRONG 7-50 & 12-75 components | 23 |
| STRONG DOUBLE 7-100 & 12-150 configuration | 24 |
| STRONG DOUBLE 7-100 & 12-150 components | 25 |
| Technical specifications. | 26 |
| Customised configuration. | 30 |
| Domestic range with PROPANE, CLASSIC P & ELITE P. | 31 |
| CLAUSIUS propane technology | 32 |
| CLASSIC propane configuration | 34 |
| ELITE propane configuration. | 35 |
| Technical specifications. | 36 |
| High power range with PROPANE, STRONG P & STRONG DOUBLE P | 37 |
| CLAUSIUS STRONG P & STRONG DOUBLE P technology | 38 |
| STRONG P 7-35, 12-55, 15-65, 15-75 & 20-95 configuration | 40 |
| Technical specifications. | 42 |
| STRONG DOUBLE P 12-115, 15-150 & 20-190 configuration. | 46 |
| Technical specifications. | 47 |
| High temperature range, HT. | 51 |
| High temperature heat pumps | 52 |
| CLAUSIUS Air source & CLAUSIUS hybrid systems | 55 |
| CLAUSIUS Air system | 56 |
| CLAUSIUS Hybrid system | 57 |
| CLAUSIUS Air units | 58 |
| CLAUSIUS Internet connection & integration with photovoltaic systems | 61 |
| New CLAUSIUS Internet connection system | 62 |
| CLAUSIUS Connection to photovoltaic systems | 63 |
| CLAUSIUS Accessories. | 65 |
| Installations with CLAUSIUS ground source heat pumps | 71 |

CLAUSIUS GROUND SOURCE HEAT PUMPS

Advantages

- **COP OF 5.01.** The highest COP reached by an inverter ground source heat pump since 2015.
- **DOMESTIC HOT WATER (DHW) UP TO 80 °C.** New DHW production system with desuperheater that allows reaching DHW temperatures up to 80 °C depending on the heat pump operating conditions.
- **HIGH POWER WITH INVERTER SYSTEM.** Up to 190 kW with the new Copeland Inverter Technology.
- **ACCESSIBILITY.** New lift opening system that allows an easy access to all components inside the unit.
- **CUSTOMISED CONFIGURATION.** CLAUSIUS ground source heat pumps can be configured according to the requirements of each installation, being able to integrate the production of active cooling, passive cooling and/or desuperheater for production of DHW at high temperature, as well as simultaneous production of heating-DHW, cooling-DHW, heating-swimming pool and cooling-swimming pool.
- **INTERNET CONNECTION, SOLAR PHOTOVOLTAIC INTEGRATION AND SMART GRID.** All our heat pumps can be connected to the Internet and are prepared for their integration with photovoltaic installations and Smart Grid.
- **PREMIUM QUALITY.** We incorporate only premium brand European components of the best existing manufacturers.
- **INTEGRATED CLIMATE CONTROL AND DHW PRODUCTION.** They integrate heating, cooling and domestic hot water services in one compact unit.
- **PASSIVE COOLING.** They allow passive cooling production with an extremely low cost and low energy consumption, exceeding Air Source heat pumps technologically.
- **SILENT.** They do not require noisy fans and do not generate air drafts, as all their components are silent and sound insulated inside the case.
- **COMFORT FOR USERS.** They are controlled with simple thermostats and do not require any user interaction, providing great comfort.
- **NO VISUAL IMPACT.** They do not require any elements on the outside, all components are buried or inside the house.
- **RELIABLE.** Twenty years 'fit and forget' lifespan. Installations with ground source heat pumps require minimal maintenance and have a long life by using a simple, proven, well-known and very reliable technology.
- **EFFICIENCY.** Market leading ErPA+++ rating. Energy efficiency and economic savings. They provide a far more energy efficiency than traditional systems and other types of heat pumps, so the cost of heating is drastically reduced, achieving significant savings.



**DOMESTIC RANGE WITH R410A,
CLASSIC & ELITE**



CLAUSIUS TECHNOLOGY

- **Inverter technology**, with three power ranges, 1 to 10 kW, 3 to 15 kW and 5 to 25 kW.

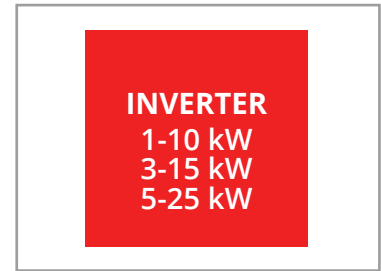

- **The highest COP in the market** for ground source heat pumps with inverter technology since 2015, certified by the Austrian Institute of Technology, according to EN14511.

- **Copeland inverter technology and scroll compressors**, the best inverter technology available in the market. We incorporate Inverter heat recovery that improves efficiency and reliability.



- **Alfa Laval asymmetric plate heat exchangers**, the most efficient heat exchange technology currently available.

- **R410A refrigerant**, maximum efficiency with low environmental impact.

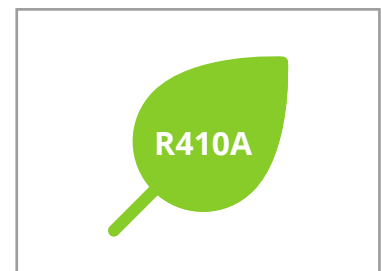

- **Carel electronic expansion valve** for an accurate control of the refrigerant flow in the evaporator.

- **Wilo high efficiency variable speed pumps (Class A)**, for an optimum flow control in both brine and heating circuits.



- **All-in-one and plug&play design.** Incorporation of circulation pumps, expansion vessels, safety valves and integrated drain valves. Ready to install.

CLAUSIUS TECHNOLOGY

- **Exclusive DHW production system up to 80 °C** without electrical heaters (patented system). No specific antilegionella treatment is required. Built in on Elite models with a tank capacity of 200 l.

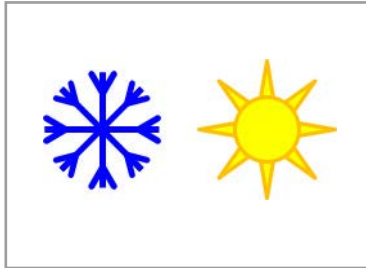

- **Customised configuration.** Our heat pumps are customised for each application, being able to select between heating and DHW production, active cooling, passive cooling and the incorporation of a desuperheater for the production of DHW at high temperature and the simultaneous production of heating and cooling with DHW or swimming pool.

- **Low acoustic level.** Specific acoustic insulation system for the compressor and the refrigeration module. Use of different insulation materials to attenuate a higher frequency range.



- **Accessibility.** New lift opening system (patented), that allows an easy access to all components inside the unit.

- **Easy and compact installation.** The inverter system allows to simplify the installations, requiring less space and reducing costs.

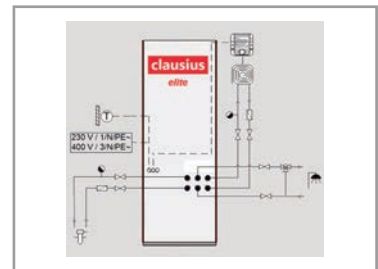

- **New control strategies.** More efficient, reliable and secure installations.

- **New online management and visualization system,** Allows remote access, preventive maintenance and provides higher reliability.

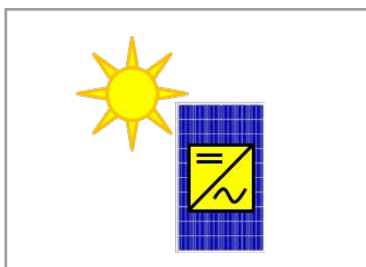
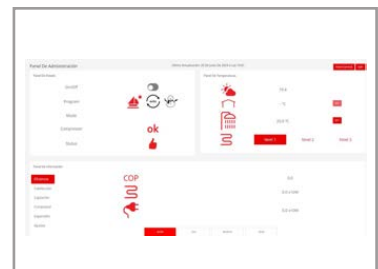

- **Connection to photovoltaic installations.** Energy surpluses management, control of the power produced by the heat pump, control of periods with different electricity rates and compatible with Smart Grid systems.

CLASSIC CONFIGURATION



- POWER ranges from 1 to 10 kW / 3 to 15 kW / 5 to 25 kW
- COPs 4.63 / 4.61 / 5.01, according to EN14511
- EERs 6.5 / 6.4 / 6.8, according to EN14511
- Single phase and three phases electrical power supply in all ranges
- R410A refrigerant
- Electronic expansion valve
- Built in Class A variable speed circulation pumps
- Built in expansion vessels and security valves
- Built in 3-way valve for DHW production
- Built in energy counters, COP, EER and SPFs
- Built in pressure sensors in both brine and heating circuits
- Minimum noise level
- New control strategies
- Control through climate regulation
- Control for 2 climate zones
- Swimming pool control
- Special programs, floor drying, air venting program, etc
- Limitation of maximum powers through software
- Possibility of cascading up to 9 units
- Tested one by one on the test bench



The highest COP in the market with inverter technology since 2015.

Copeland inverter technology.



CUSTOMISED CONFIGURATION

- Optional integration of a passive cooling system
- Optional integration of a desuperheater system for high temperature DHW production and simultaneous production of heating and DHW or swimming pool, and cooling with DHW or swimming pool
- Optional control with "Clausius Advance Control"



MODELS IN THREE POWER RANGES, 1-10 KW, 3-15 KW Y 5-25 KW

| | |
|----------|--|
| H | Heating |
| HC | Heating and active cooling |
| H PC | Heating and passive cooling |
| HC PC | Heating active cooling and built-in passive cooling |
| H DS | Heating and desuperheater |
| HC DS | Heating active cooling and desuperheater |
| H PC DS | Heating built-in passive cooling and desuperheater |
| HC PC DS | Heating active cooling, built-in passive cooling and desuperheater |

CLASSIC COMPONENTS

In the manufacture of CLAUDIUS ground source heat pumps, we only use components from the European premium brands.

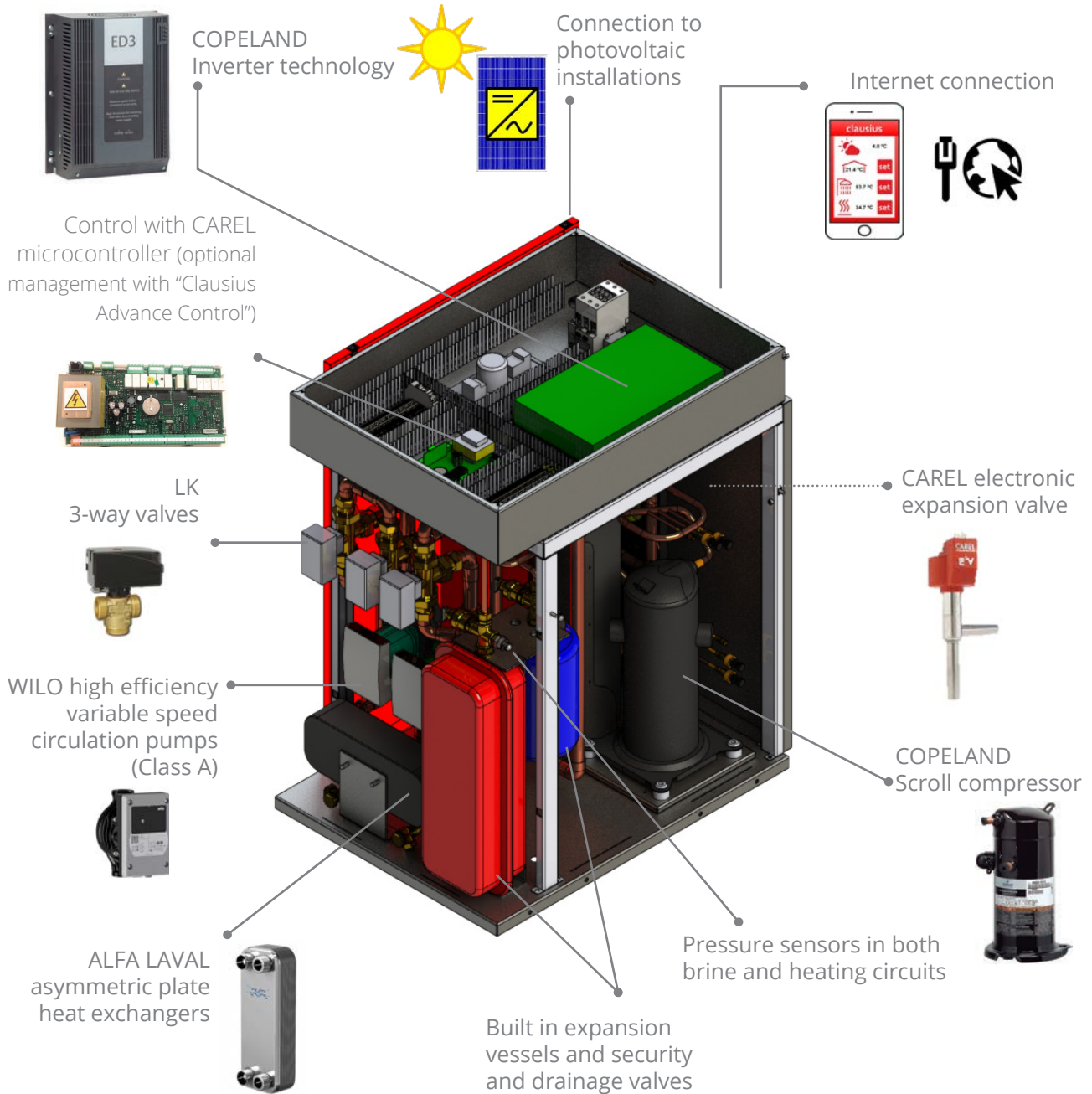

WE MANUFACTURE WITH THE BEST COMPONENTS IN THE MARKET



ELITE CONFIGURATION



- 200 l DHW tank made of stainless steel AISI 316
- DHW production system up to 80 °C without electric heaters, through a built-in desuperheater
- Power ranges from 1 to 10 kW / 3 to 15 kW / 5 to 25 kW
- COPs 4.63 / 4.61 / 5.01, according to EN14511
- EERs 6.5 / 6.4 / 6.8, according to EN14511
- Single phase and three phases electrical power supply in all ranges
- R410A refrigerant
- Electronic expansion valve
- Built in expansion vessels and security and drainage valves
- Built in Class A variable speed circulation pumps
- Built in energy counters, COP, EER and SPF
- Built in pressure sensors in both brine and heating circuits
- Minimum noise level
- New control strategies
- Control through climate regulation
- Control of 2 climate zones
- Swimming pool control
- Special programs, floor drying, air venting program, etc
- Limitation of maximum powers through software
- Possibility of cascading up to 9 units
- Tested one by one on the test bench



DHW production system up to 80 °C, patented system.

200 liters of hot water up to 80 °C without electric heaters.

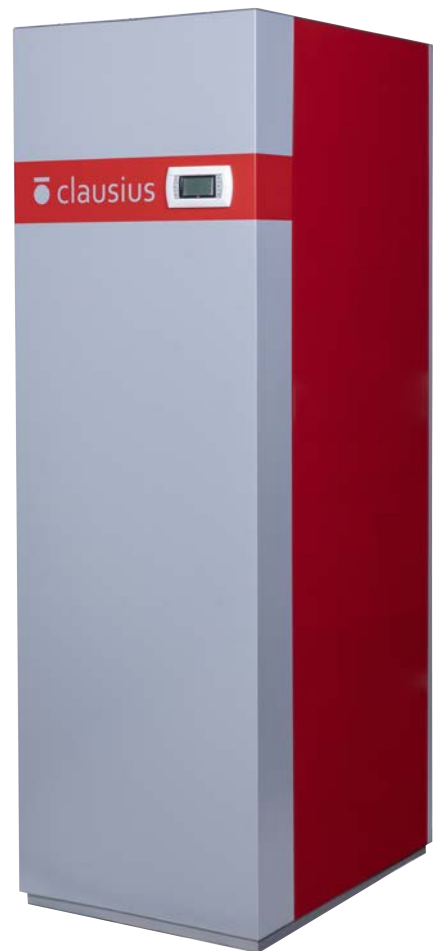

CUSTOMISED CONFIGURATION

- Optional integration of a passive cooling system
- Optional control with "Clausius Advance Control"



MODELS IN THREE POWER RANGES, 1-10 KW, 3-15 KW AND 5-25 KW

| | |
|-------|--|
| H | Heating and DHW production with a built-in tank |
| HC | Heating, DHW production with a built-in tank and active cooling |
| H PC | Heating, DHW production with a built-in tank and passive cooling |
| HC PC | Heating, DHW production with a built-in tank, active and passive cooling |

ELITE COMPONENTS

Elite configuration includes a DHW tank made of stainless steel AISI 316 with 200 l capacity and built-in desuperheater, which allows DHW temperatures up to 80°C.

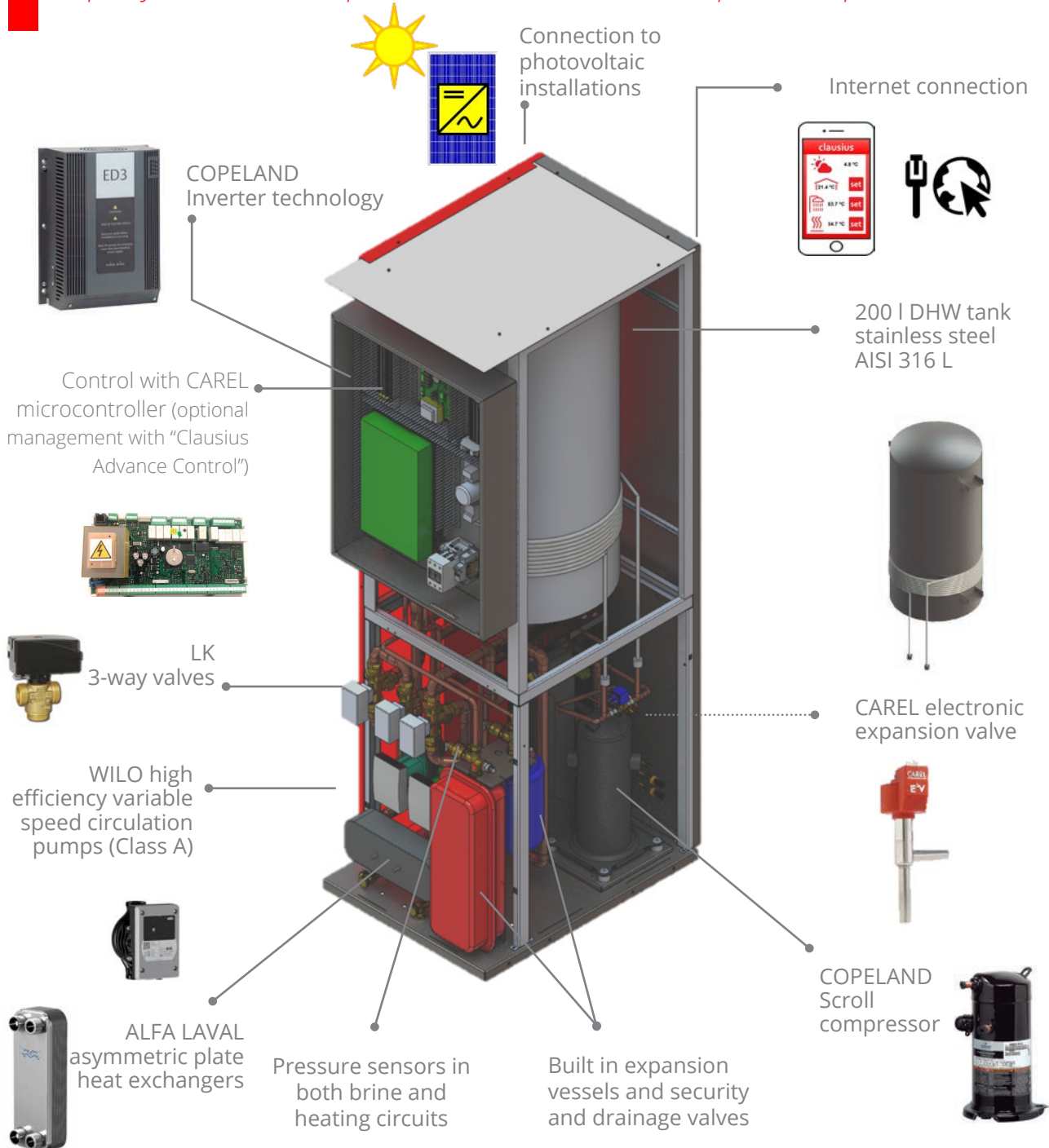

WE MANUFACTURE WITH THE BEST COMPONENTS IN THE MARKET



TECHNICAL SPECIFICATIONS

| | | H 1-10 (classic / elite) | HC 1-10 (classic / elite) | H 3-15 (classic / elite) | HC 3-15 (classic / elite) | H 5-25 (classic / elite) | HC 5-25 (classic / elite) |
|-----------------------|---|---|-------------------------------|-------------------------------|-------------------------------|-------------------------------|-------------------------------|
| Applications | Heating and DHW | • | • | • | • | • | • |
| | Active cooling | | • | | • | | • |
| Optional applications | Passive cooling | • | • | • | • | • | • |
| | High temperature DHW with desuperheater | • / - | • / - | • / - | • / - | • / - | • / - |
| Power | Heating (kW) | 1 - 10 | 1 - 10 | 3 - 15 | 3 - 15 | 5 - 25 | 5 - 25 |
| | Active cooling (kW) | | 2 - 11 | | 4 - 16.5 | | 7 - 30 |
| | Electrical consumption (kW) | 0.4 - 2.1 | 0.4 - 2.1 | 0.8 - 3.3 | 0.8 - 3.3 | 1.3 - 5.6 | 1.3 - 5.6 |
| Power supply | 230 V 1/N/PE ⁻ | • | • | • | • | • | • |
| | 400 V 3/N/PE ⁻ | • | • | • | • | • | • |
| Performance | COP ¹ | 4.63 | 4.63 | 4.61 | 4.61 | 5.01 | 5.01 |
| | EER ¹ | | 6.5 | | 6.4 | | 6.8 |
| DHW Tank | | External / Integrated (200 l) | External / Integrated (200 l) | External / Integrated (200 l) | External / Integrated (200 l) | External / Integrated (200 l) | External / Integrated (200 l) |
| Refrigerant | Type | R410A | | | | | |
| | Load (kg) | 1.1 / 1.2 | 1.2 / 1.3 | 1.1 / 1.2 | 1.2 / 1.3 | 1.6 / 1.7 | 1.7 / 1.8 |
| Flow | Brine Min / Max (l/h) | 239 / 2394 | | 717 / 3587 | | 1222 / 6110 | |
| | Heating Min / Max (l/h) | 172 / 1722 | | 517 / 2584 | | 861 / 4306 | |
| Temperature | Min / Max (°C) | Brine = -15 / +20 | | | Heating = +25 / +57 | | |
| Pressure drop | Maximum | 38.9 / 15.4 | | 81.1 / 32.3 | | 99.4 / 39.5 | |
| Dimensions | Height x Width x Depth (mm) | Classic 1040 x 600 x 800 / Elite 1878 x 600 x 800 | | | | | |
| Connections | Brine and heating | 1" | | | | | |
| | DHW | Classic 1" / Elite 3/4" | | | | | |
| Weight | (kg) | 147 / 227 | 158 / 238 | 163 / 243 | 174 / 254 | 168 / 248 | 179 / 259 |
| Sound level | (dB) | 42 | | | | | |

⁽¹⁾According to EN14511 and EN14825.



A+++

Energy labelling, product sheets and technical documentation according to **Delegated Regulation (UE) N° 811/2013.**

OPTIONAL EQUIPMENT

Built-in desuperheater in CLASSIC models

In CLASSIC configuration and in all H and HC models, a system with desuperheater can be integrated (DS).

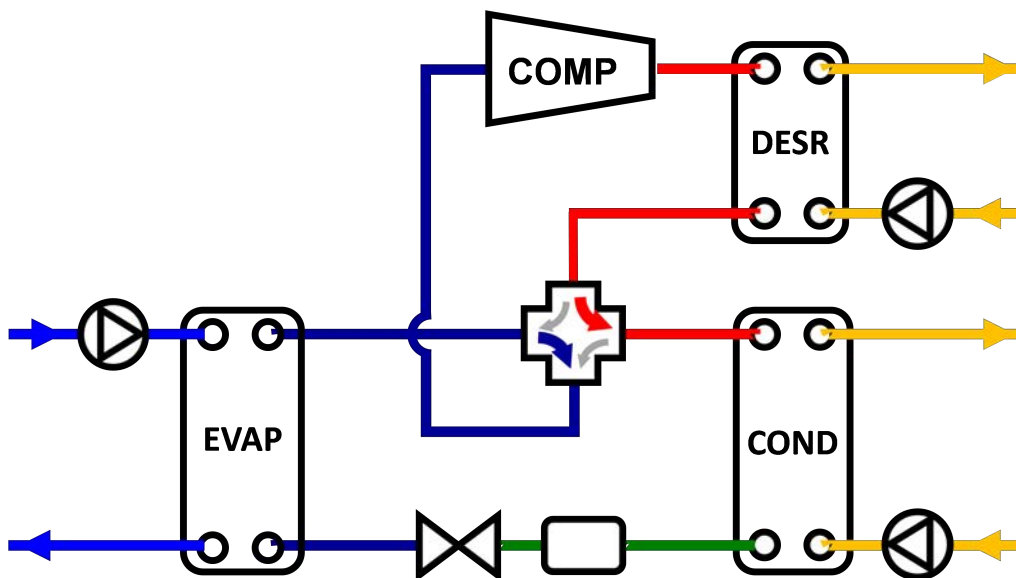

Simplified scheme of a CLASSIC HC with desuperheater.

The system with desuperheater allows the production of DHW at high temperature, as well as a simultaneous production of heating and DHW or swimming pool and cooling with DHW or swimming pool in HC DS models.

The desuperheater system consists of one heat exchanger (desuperheater), a circulation pump and the corresponding valves and control system. Our desuperheater system allows:

- Simultaneous production of heating and DHW at high temperature.
- Simultaneous production of cooling and DHW at high temperature.
- Simultaneous production of heating and swimming pool.
- Simultaneous production of cooling and swimming pool.
- Production of only DHW and pool using the condenser and desuperheater simultaneously, which increases the efficiency of the heat pump in these processes.

OPTIONAL EQUIPMENT

Passive cooling in CLASSIC & ELITE

In CLASSIC and ELITE configurations and in all H and HC models, we can integrate a passive cooling production system (PC).

The passive cooling system consists of one heat exchanger and its corresponding 3-way valves in both brine and heating circuits.

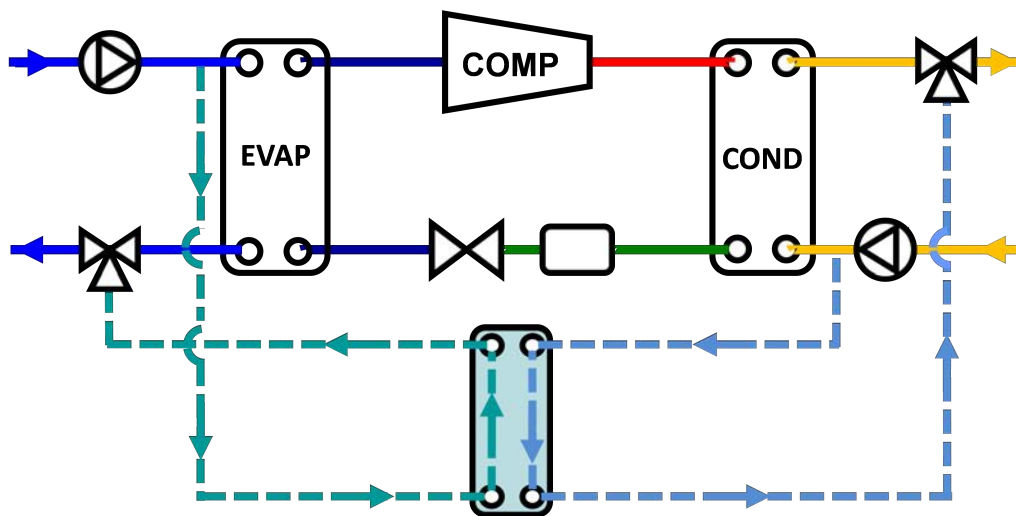

Simplified scheme of the passive cooling production system.

In all models, activation and control of passive cooling production is carried out by the heat pump itself. In models HC PC, it is possible to select between different options, only passive cooling production, only active cooling production, or both. In case of using both systems (passive and active cooling), the heat pump always decides the optimal production system, giving priority to passive cooling.

CLAUSIUS Advance Control

In CLASSIC and ELITE configurations and in all models, we can integrate the CLAUSIUS Advance Control system.

The unique CLAUSIUS "Advance Control System" has been specifically designed by CLAUSIUS, allowing the control of complex installations, and of the CLAUSIUS Hybrid System.

OPTIONAL EQUIPMENT

CLAUSIUS Advance Control incorporates all the functionalities of the CLAUSIUS Standard control system. Furthermore, it adds the features that are detailed below.

- Control of 4 mixing groups.
- Independent control of 6 zones with heating and cooling thermostats.
- Control of the DHW recirculation system by temperature.
- Control of 3 in-line electric heaters.
- Control with flow switches in both brine and heating circuits.
- Simultaneous use of Th-tunes and Internet Kit.
- Indoor temperature and humidity measurements.
- Control of bivalent systems through on-off of the complementary system.
- Control of secondary circuits from the buffer tank.
- Control of the CLAUSIUS ground-air source hybrid system.

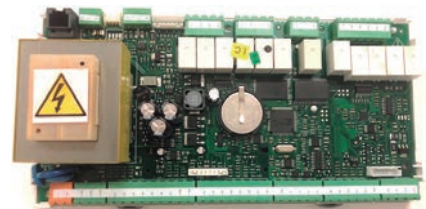
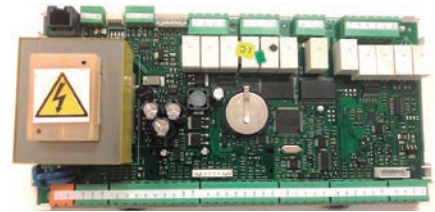

White finish, TULIP WHITE

All models in CLASSIC and ELITE configurations are also available in white finish.



CUSTOMISED CONFIGURATION

You can customise your CLAUSIUS domestic heat pumps for each application.

1°.- Choose configuration

- CLASSIC, without built-in DHW tank
- ELITE, with built-in DHW tank

2°.- Choose base model

- H, heating and DHW
- HC, heating, DHW and active cooling

3°.- Choose heating power range and power supply

- 1-10, power range from 1 to 10 kW single phase
- 1-10 T, power range from 1 to 10 kW three phases
- 3-15, power range from 3 to 15 kW single phase
- 3-15 T, power range from 3 to 15 kW three phases
- 5-25, power range from 5 to 25 kW single phase
- 5-25 T, power range from 5 to 25 kW three phases

4°.- Add optional equipment

- PC, built-in passive cooling in all models and power ranges
- DS, desuperheater in CLASSIC models and all power ranges

5°.- Choose finishes

- Red CLAUSIUS finish
- Tulip White finish

6°.- Choose accessories

- Advance control
- Internet connection kit
- Photovoltaic solar meter
- Th-Tune control thermostat
- Replacement of standard circulation pump (11 mwc) by the same model with 15 mwc
- RF/WIFI Control Thermostat
- 1500 W or 2000 W electric heater with thermostat for DHW tanks

A low-angle, upward-looking photograph of a massive steel lattice tower, likely a suspension bridge tower. The structure is composed of numerous interconnected steel beams and girders, creating a complex geometric pattern. The sky is a clear, pale blue. The image is framed by a red border on the right and bottom sides. A red horizontal band is superimposed over the middle of the image, containing white text.

**HIGH POWER RANGE WITH R410A,
STRONG & STRONG DOUBLE**

CLAUSIUS STRONG 7-50 & 12-75 TECHNOLOGY

- **Inverter technology with the widest power range in the market**, from 7 to 50 kW and from 12 to 75 kW.



INVERTER

7-50 kW
12-75 kW

- **We are the first manufacturer to use the new high power Copeland scroll compressors and inverters.**

- **Customised configuration.** Our heat pumps are customised for each application, being able to select between heating and DHW production, active cooling, passive cooling and the incorporation of a desuperheater for the production of DHW at high temperature and the simultaneous production of heating and cooling with DHW or swimming pool.

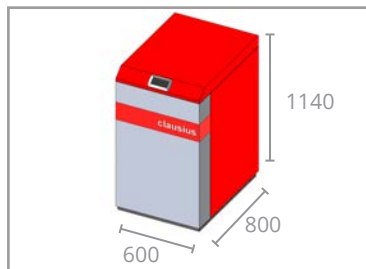
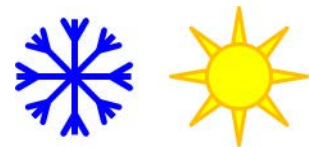

- **High power in a minimum space.** Up to 75 kW in a 600 mm x 800 mm x 1140 mm case (width x depth x height).

- **Accessibility.** Lift opening system (patented) that allows an easy access to all components inside the unit.



- **New control strategies.** More efficient, reliable and secure installations.

- **New Internet Management and Visualization System**, enabling remote access, preventive maintenance, and enhanced heat pump reliability,

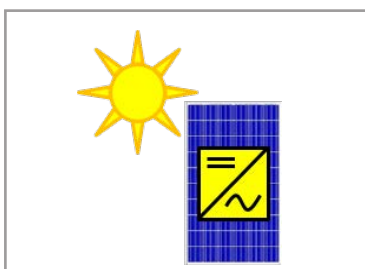
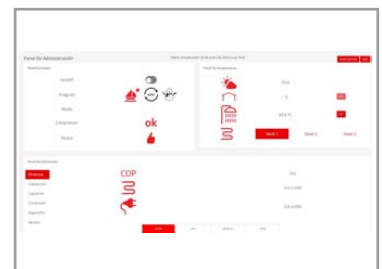

- **Connection to photovoltaic installations.** Energy surpluses management, control of the power produced by the heat pump, control of periods with different electricity rates and compatible with Smart Grid systems.

CLAUSIUS STRONG DOUBLE 7-100 & 12-150 TECHNOLOGY

- **Inverter technology with the widest power range in the market**, from 7 to 100 kW and from 12 to 150 kW.

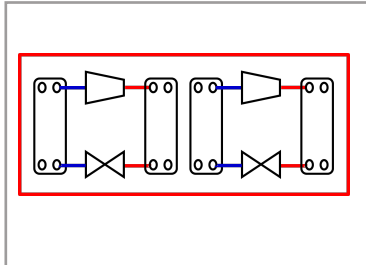

INVERTER

7-100 kW
12-150 kW

- **Double refrigerant circuit, double reliability.** STRONG DOUBLE units consist of 2 totally independent refrigerant circuits, each one equipped with its own inverter system, so that each of them can work completely independent, which gives the unit double reliability.

- **Maximum efficiency by controlling the optimal operational point.** At any time, the control system establishes the optimal operational conditions considering the operation of both refrigerant circuits.

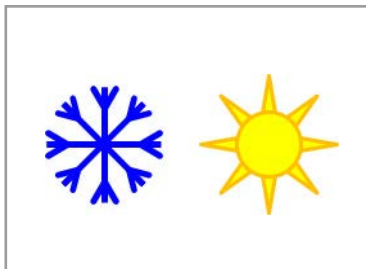

- **Customised configuration.** Our heat pumps are customised for each application being able to select between heating and DHW production, active cooling, and the integration of a desuperheater.

- **Built-in desuperheater for high temperature DHW production** (optional). Independent DHW production circuit. New control system with flow regulation in the desuperheater for DHW production up to 60/65 °C.



- **Accessibility.** Lift opening system that allows an easy access to all components inside the unit.

- **New control strategies.** More efficient, reliable and secure installations.

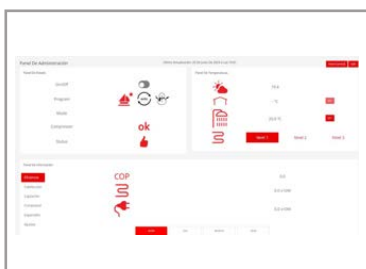
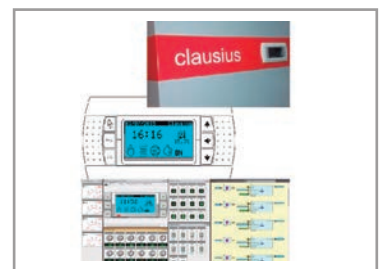

- **New Internet Management and Visualization System**, enabling remote access, preventive maintenance, and enhanced heat pump reliability.

- **Connection to photovoltaic installations.** Energy surpluses management, control of the power produced by the heat pump, control of periods with different electricity rates and compatible with Smart Grid systems.

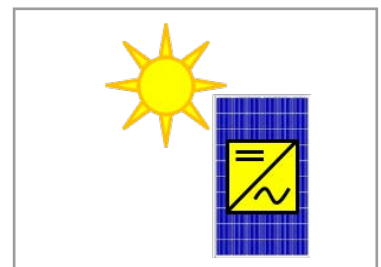

High power range with R410A, STRONG

STRONG 7-50 & 12-75 CONFIGURATION



- Power ranges from 7 to 50 kW and from 12 to 75 kW
- COP 4.8 according to EN14511
- EER 6.5 according to EN14511
- Three phases electrical power supply
- Active cooling integrated
- Refrigerant R410A
- Electronic expansion valve
- Energy meters integrated, COP, EER and SPFs
- Built in pressure sensors in both brine circuit and heating circuit
- Market leading noise reduction
- Control based on 2 microcontrollers
- New control strategies
- Swimming pool control
- Control of 5 mixing groups and 6 climate zones
- External passive cooling control
- Possibility of cascading up to 9 units
- Tested one by one on the test bench



High power with the new Copeland inverter technology.



- CUSTOMISED CONFIGURATION**
- Built-in passive cooling, optional
 - Built-in desuperheater for high temperature DHW production, optional



MODELS IN TWO POWER RANGES, 7-50 KW AND 12-75 KW

| | |
|----------|--|
| H | Heating |
| HC | Heating & active cooling |
| H PC | Heating & passive cooling |
| HC PC | Heating, active & passive cooling |
| H DS | Heating & desuperheater |
| HC DS | Heating, active cooling & desuperheater |
| H PC DS | Heating, passive cooling & desuperheater |
| HC PC DS | Heating, active cooling, passive cooling & desuperheater |

STRONG DOUBLE 7-100 & 12-150 CONFIGURATION



- Power ranges from 7 to 100 kW and 12 to 150 kW
- COP 4.7, according to EN14511
- EER 6.5, according to EN14511
- Three phases electrical power supply
- Active cooling integrated
- R410A refrigerant
- Electronic expansion valve
- Energy meters integrated, COP, EER and SPFs
- Built in pressure sensors in both brine circuit and heating circuit
- Market leading noise reduction
- New control strategies
- Control with 3 microcontrollers
- Control of 5 mixing groups and 6 climate zones
- Swimming pool control
- External passive cooling control
- Possibility of cascading up to 6 units
- Tested one by one on the test bench



Two totally independent refrigerant circuits, double reliability.

Inverter system in each circuit, maximum efficiency at any time.



CUSTOMISED CONFIGURATION

- Built-in desuperheater for high temperature DHW production, optional



MODELS IN TWO POWER RANGES, 7-100 KW AND 12-150 KW

| | |
|-------|---|
| H | Heating |
| HC | Heating & active cooling |
| H DS | Heating & desuperheater |
| HC DS | Heating, active cooling & desuperheater |

STRONG DOUBLE 7-100 & 12-150 COMPONENTS

Double refrigerant circuit with totally independent inverter systems

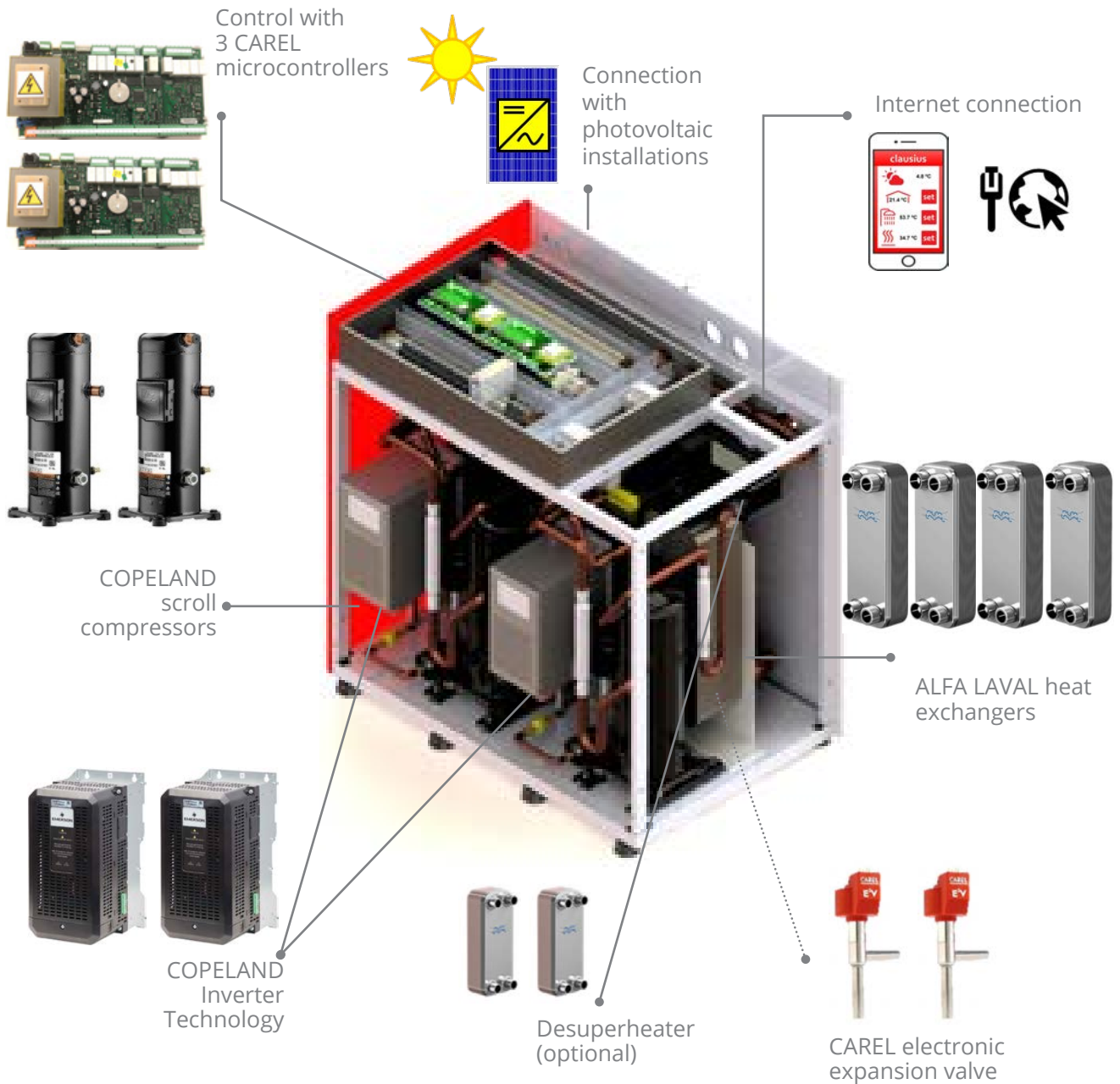

WE MANUFACTURE WITH THE BEST COMPONENTS IN THE MARKET



TECHNICAL SPECIFICATIONS STRONG 7-50

| | | H 7-50 | H 7 - 50 PC | H 7 - 50 DS | H 7 - 50 PC DS | HC 7-50 | HC 7 - 50 PC | HC 7 - 50 DS | HC 7 - 50 PC DS |
|-----------------------------|---|-------------------|----------------|----------------|-------------------|---------------------|-----------------|-----------------|--------------------|
| Applications | Heating and DHW | • | • | • | • | • | • | • | • |
| | Active cooling | | | | | • | • | • | • |
| Optional applications | Passive cooling | | • | | • | | • | | • |
| | High temperature DHW with desuperheater | | | • | • | | | • | • |
| External components control | Circulation pumps control | • | • | • | • | • | • | • | • |
| | DHW control | • | • | • | • | • | • | • | • |
| | External passive cooling control | • | | • | | • | | • | |
| | Pool control | • | • | • | • | • | • | • | • |
| | Mixing groups control | • | • | • | • | • | • | • | • |
| | Electric heaters control | • | • | • | • | • | • | • | • |
| Power | Heating (kW) | 7-50 | 7-50 | 7-50 | 7-50 | 7-50 | 7-50 | 7-50 | 7-50 |
| | Active cooling (kW) | | | | | 9-52 | 9-52 | 9-52 | 9-52 |
| | Passive cooling (kW) | | 20 | | 20 | | 20 | | 20 |
| | Desuperheater ⁽²⁾ (kW) | | | 14 / 32 | 14 / 32 | | | 14 / 32 | 14 / 32 |
| Electrical supply | 3 ph - 400 V | | | | | | | | |
| Electrical power | Maximum | 17 kW | | | | | | | |
| Performance | COP ⁽¹⁾ | 4.48 | 4.48 | 4.48 | 4.48 | 4.48 | 4.48 | 4.48 | 4.48 |
| | EER ⁽¹⁾ | | | | | 6.7 | 6.7 | 6.7 | 6.7 |
| | SCOP ⁽¹⁾ | 5.10 | 5.10 | 5.10 | 5.10 | 5.10 | 5.10 | 5.10 | 5.10 |
| Refrigerant | Type | R410A | | | | | | | |
| | Load (kg) | 3.2 | 3.2 | 3.4 | 3.4 | 3.3 | 3.3 | 3.5 | 3.5 |
| Flow | Brine Min / Max (l/h) | 1660 / 11859 | | | | | | | |
| | Heating Min / Max (l/h) | 1206 / 8612 | | | | | | | |
| Temperatures | Min / Max (°C) | Brine = -15 / +20 | | | | Heating = +25 / +57 | | | |
| Pressure Drop | Maximum (kPa) | Brine = 45.3 | | | | Heating = 19.1 | | | |
| Dimensions | Height x Width x Depth (mm) | 1240 x 600 x 800 | | | | | | | |
| Connections | Brine and heating | 2" | | | | | | | |
| | High temperature DHW | | | 1 1/4" | 1 1/4" | | | 1 1/4" | 1 1/4" |
| Weight | (kg) | 238 | 256 | 246 | 264 | 240 | 248 | 258 | 268 |
| Sound level | (dB) | 52 | | | | | | | |

⁽¹⁾ According to EN14511 and EN14825. ⁽²⁾ Brine: 0/-3 °C, Heating: 50/55 °C, DHW: 65 °C / Desuperheater as a condenser Brine: 0/-3, DHW: 45 °C

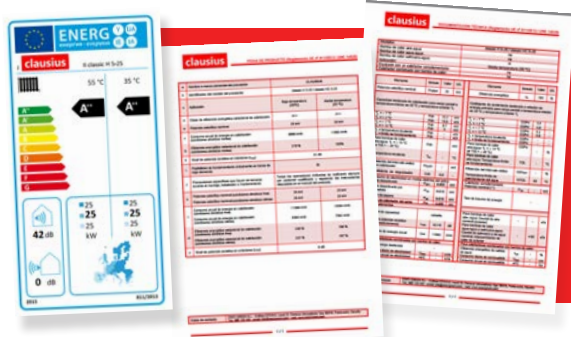

Energy labelling, product sheets and technical documentation according to **Delegated Regulation (UE) N° 811/2013**

A+++

TECHNICAL SPECIFICATIONS STRONG 12-75

| | | H 12-75 | H 12 - 75 PC | H 12 - 75 DS | H 12 - 75 PC DS | HC 12-75 | HC 12-75 PC | HC 12-75 DS | HC 12-75 PC DS |
|-----------------------------|---|-------------------|-----------------|-----------------|--------------------|---------------------|----------------|----------------|-------------------|
| Applications | Heating and DHW | • | • | • | • | • | • | • | • |
| | Active cooling | | | | | • | • | • | • |
| Optional applications | Passive cooling | | • | | • | | • | | • |
| | High temperature DHW with desuperheater | | | • | • | | | • | • |
| External components control | Circulation pumps control | • | • | • | • | • | • | • | • |
| | DHW control | • | • | • | • | • | • | • | • |
| | External passive cooling control | • | | • | | • | | • | |
| | Pool control | • | • | • | • | • | • | • | • |
| | Mixing groups control | • | • | • | • | • | • | • | • |
| | Electric heaters control | • | • | • | • | • | • | • | • |
| Power | Heating (kW) | 12-75 | 12-75 | 12-75 | 12-75 | 12-75 | 12-75 | 12-75 | 12-75 |
| | Active cooling (kW) | | | | | 14-78 | 14-78 | 14-78 | 14-78 |
| | Passive cooling (kW) | | 20 | | 20 | | 20 | | 20 |
| | Desuperheater ⁽²⁾ (kW) | | | 19 / 41 | 19 / 41 | | | 19 / 41 | 19 / 41 |
| Electrical supply | 3 ph - 400 V | | | | | | | | |
| Electrical power | Maximum | 20 kW | | | | | | | |
| Performance | COP ⁽¹⁾ | 4.81 | 4.81 | 4.81 | 4.81 | 4.81 | 4.81 | 4.81 | 4.81 |
| | EER ⁽¹⁾ | | | | | 6.7 | 6.7 | 6.7 | 6.7 |
| | SCOP ⁽¹⁾ | 5.24 | 5.24 | 5.24 | 5.24 | 5.24 | 5.24 | 5.24 | 5.24 |
| Refrigerant | Type | R410A | | | | | | | |
| | Load (kg) | 3.6 | 3.6 | 3.8 | 3.8 | 3.8 | 3.8 | 4.2 | 4.2 |
| Flow | Brine Min / Max (l/h) | 2902 / 18140 | | | | | | | |
| | Heating Min / Max (l/h) | 2067 / 12919 | | | | | | | |
| Temperatures | Min / Max (°C) | Brine = -15 / +20 | | | | Heating = +25 / +57 | | | |
| Pressure Drop | Maximum (kPa) | Brine = 55.2 | | | | Heating = 22.7 | | | |
| Dimensions | Height x Width x Depth (mm) | 1240 x 600 x 800 | | | | | | | |
| Connections | Brine and heating | 2" | | | | | | | |
| | High temperature DHW | | | 1 1/4" | 1 1/4" | | | 1 1/4" | 1 1/4" |
| Weight | (kg) | 252 | 270 | 261 | 279 | 267 | 284 | 275 | 293 |
| Sound level | (dB) | 52 | | | | | | | |

⁽¹⁾ According to EN14511 and EN14825. ⁽²⁾ Brine: 0/-3 °C, Heating: 50/55 °C, DHW: 65 °C / Desuperheater as a condenser Brine: 0/-3, DHW: 45 °C



A+++

Energy labelling, product sheets and technical documentation according to Delegated Regulation (UE) N° 811/2013

TECHNICAL SPECIFICATIONS STRONG DOUBLE 7-100

| | | H 7-100 | H 7 - 100 DS | HC 7-100 | HC 7 - 100 DS |
|-----------------------------|---|---------------------------------------|--------------|----------------|---------------|
| Applications | Heating and DHW | • | • | • | • |
| | Active cooling | | | • | • |
| Optional application | High temperature DHW with desuperheater | | • | | • |
| External components control | Circulations pump control | • | • | • | • |
| | DHW control | • | • | • | • |
| | External passive cooling control | • | • | • | • |
| | Swimming pool control | • | • | • | • |
| | Mixing groups control | • | • | • | • |
| | Electric heaters control | • | • | • | • |
| Power | Heating (kW) | 7-100 | 7-100 | 7-100 | 7-100 |
| | Active cooling (kW) | | | 9-112 | 9-112 |
| | Desuperheater (kW) ⁽²⁾ | | 28 / 63 | | 25 / 63 |
| Electrical supply | 3 ph - 400 V | | | | |
| Electrical power | Maximum | 34 kW | | | |
| Performance | COP ⁽¹⁾ | 4.48 | 4.48 | 4.48 | 4.48 |
| | EER ⁽¹⁾ | | | 6.5 | 6.5 |
| | SCOP ⁽¹⁾ | 5.10 | 5.10 | 5.10 | 5.10 |
| Refrigerant | Type | R410A | | | |
| | Load (kg) | 6.4 | 6.8 | 6.6 | 7.0 |
| Flow | Brine Min / Max (l/h) | 1660 / 23719 | | | |
| | Heating Min / Max (l/h) | 1206 / 17225 | | | |
| Temperatures | Min / Max (°C) | Brine = -15 / +20 Heating = +25 / +57 | | | |
| Pressure Drop | Maximum (kPa) | Brine = 45.3 | | Heating = 19.1 | |
| Dimensions | Height x Width x Depth (mm) | 1140 x 760 x 1150 | | | |
| Connections size | Brine and heating | 3" | | | |
| | Desuperheater (optional) | 1 1/2" | | 1 1/2" | |
| Weight | (kg) | 414 | 419 | 430 | 435 |
| Sound level ⁽²⁾ | (dB) | 65 | | | |

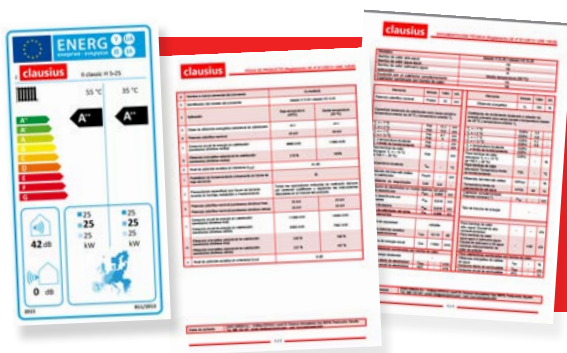
⁽¹⁾According to EN14511 and EN14825. ⁽²⁾Brine: 0/-3 °C, Heating: 50/55 °C, DHW: 65 °C / Desuperheater as a condenser Brine: 0/-3, DHW: 45 °C



Energy labelling, product sheets and technical documentation according to **Delegated Regulation (UE) N° 811/2013**

A+++

TECHNICAL SPECIFICATIONS STRONG DOUBLE 12-150

| | | H 12-150 | H 12 - 150 DS | HC 12-150 | HC 12 - 150 DS |
|-----------------------------|---|---------------------------------------|---------------|-----------|----------------|
| Applications | Heating and DHW | • | • | • | • |
| | Active cooling | | | • | • |
| Optional application | High temperature DHW with desuperheater | | • | | • |
| External components control | Circulations pump control | • | • | • | • |
| | DHW control | • | • | • | • |
| | External passive cooling control | • | • | • | • |
| | Swimming pool control | • | • | • | • |
| | Mixing groups control | • | • | • | • |
| | Electric heaters control | • | • | • | • |
| Power | Heating (kW) | 12-150 | 12-150 | 12-150 | 12-150 |
| | Active cooling (kW) | | | 14-156 | 14-156 |
| | Desuperheater (kW) ⁽²⁾ | | 39 / 82 | | 39 / 82 |
| Electrical supply | 3 ph - 400 V | | | | |
| Electrical power | Maximum | 40 kW | | | |
| Performance | COP ⁽¹⁾ | 4.81 | 4.81 | 4.81 | 4.81 |
| | EER ⁽¹⁾ | | | 6.5 | 6.5 |
| | SCOP ⁽¹⁾ | 5.24 | 5.24 | 5.24 | 5.24 |
| Refrigerant | Type | R410A | | | |
| | Load (kg) | 7.2 | 7.6 | 7.6 | 8.4 |
| Flow | Brine Min / Max (l/h) | 2902 / 36279 | | | |
| | Heating Min / Max (l/h) | 2067 / 25837 | | | |
| Temperatures | Min / Max (°C) | Brine = -15 / +20 Heating = +25 / +57 | | | |
| Pressure Drop | Maximum (kPa) | Brine = 55.2 Heating = 22.7 | | | |
| Dimensions | Height x Width x Depth (mm) | 1140 x 760 x 1150 | | | |
| Connections size | Brine and heating | 3" | | | |
| | Desuperheater (optional) | 1 1/2" | | 1 1/2" | |
| Weight | (kg) | 469 | 474 | 485 | 490 |
| Sound level ⁽²⁾ | (dB) | 68 | | | |

⁽¹⁾ According to EN14511 and EN14825. ⁽²⁾ Brine: 0/-3 °C, Heating: 50/55 °C, DHW: 65 °C / Desuperheater as a condenser Brine: 0/-3, DHW: 45 °C



A+++

Energy labelling, product sheets and technical documentation according to **Delegated Regulation (UE) N° 811/2013**

CUSTOMISED CONFIGURATION

You can customise your CLAUSIUS high power STRONG and STRONG DOUBLE heat pumps for each application.

1°.- Choose base model

- H, heating and DHW
- HC, heating, DHW and active cooling

2°.- Choose heating power range

- 7-50, power range from 7 to 50 kW
- 12-75, power range from 12 to 75 kW
- 7-100, power range from 7 to 100 kW
- 12-150, power range from 12 to 150 kW

3°.- Add optional equipment

- DS, desuperheater available in all STRONG and STRONG DOUBLE models and power ranges
- PC, built-in passive cooling available only in STRONG models

4°.- Choose finishes

- Red CLAUSIUS finish
- Tulip White finish

5°.- Choose accessories

- Internet connection kit
- Photovoltaic solar module
- Th-Tune control thermostat
- RF/WIFI Control Thermostat

For special applications, contact CLAUSIUS directly to prepare a customised configuration from both a hardware and software point of view.

**DOMESTIC RANGE WITH PROPANE,
CLASSIC P & ELITE P**



CLAUSIUS propane technology

NEW!

WE ARE THE FIRST HEAT PUMP MANUFACTURER TO INCORPORATE FLOW METERS IN BRINE AND HEATING CIRCUITS.

CLAUSIUS IS THE FIRST MANUFACTURER to integrate **flow meters** into propane heat pumps, responding to a long-standing demand from our customers.

Real-time flow measurement enhances the safety and operational reliability of the heat pump, providing continuous insight into its operating conditions. This enables precise system monitoring, supports operational optimisation, and ultimately improves overall efficiency and long-term reliability.

The new **CLAUSIUS propane heat pumps** implement **ultrasonic flow meters, pressure sensors and temperature sensors** in the brine and heating circuits, allowing us to measure and use the following parameters into the control system.

- The **flow rate** circulating through the brine, heating and DHW production circuits.
- The **supply and return temperatures** in brine, heating and DHW production circuits.
- The **power** obtained in the brine circuit and transferred to the heating circuit and DHW production.
- The **pressure** in the brine and heating circuits.
- The **glycol concentration** in the circuits.
- The **detection of air bubbles** in the circuits.



NEW!



- **PROPANE AS A REFRIGERANT.** Propane is the refrigerant of the future in ground source heat pumps due to its low heating potential (GWP = 3) and its excellent thermodynamic properties.

- Propane enables higher condensing temperatures than traditional refrigerants, allowing higher flow temperatures for heating and DHW production to be achieved through a simple compression system without the need of desuperheaters.
- CLAUSIUS ground source heat pumps with propane are capable to deliver water flow temperatures between 65 and 70 °C.
- Heat pumps with propane as a refrigerant are a key technology for the decarbonisation of climate control systems in the future.

NEW!

- **WE ARE THE MANUFACTURER THAT PROVIDES THE MAXIMUM POWER PER GRAM OF PROPANE.** The use of the latest generation of Alfa Laval asymmetric heat exchangers, specially designed to minimise the propane load, as well as the new design of the refrigerant circuit, **minimise the amount of propane required per thermal kW obtained from** the heat pump.

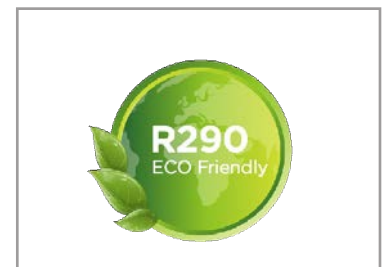

NEW!

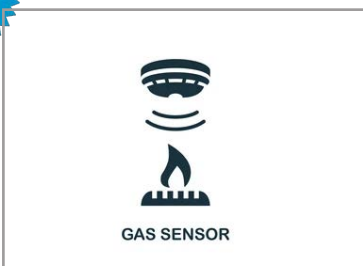

- **SAFETY WITH PROPANE.** Propane is a flammable refrigerant (A3), so safety is a very important concern. Clausius heat pumps with propane are equipped with a propane detector and a leakage control system for indoor installation (models with a propane charge of more than 150 g).

CLAUSIUS propane technology



• **WE INCORPORATE THE LATEST GENERATION OF COPELAND LOW NOISE COMPRESSORS AND NEW INVERTERS.** The new Copeland low noise compressors have been specially designed and optimised to be used with propane.

- They achieve a noise reduction of up to 10 dB while increasing the seasonal efficiency of the heat pump by up to 7%, as a result of their next-generation electric motors, an advanced scroll geometry, and optimised refrigerant vapour flow within the compressor.
- They have a wider operating map than R410A compressors, allowing to increase the range of the heat pump operating conditions and to achieve higher heating flow temperatures.
- The inverter system allows a linear modulation of the power produced, which results in higher seasonal efficiencies. In addition, a heat recovery and a temperature control system are incorporated into the inverter, which provides more efficiency and reliability.



- **WE INCORPORATE ALFA LAVAL ASYMMETRIC PLATE HEAT EXCHANGERS, SPECIALLY DESIGNED FOR PROPANE.** The most efficient heat exchanger technology available, specifically designed to minimize propane load in heat pumps.



• **NEW INTERNET-BASED MANAGEMENT AND VISUALIZATION SYSTEM,** enabling remote access, preventive maintenance, and providing greater reliability for the heat pump.



- **CAREL ELECTRONIC EXPANSION VALVE,** for an accurate control of the refrigerant flow in the evaporator.

- **WILO HIGH EFFICIENCY VARIABLE SPEED PUMPS (CLASS A),** for an optimum flow control in both brine and heating circuits.

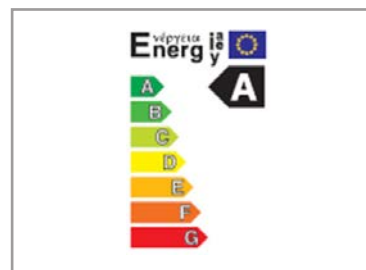

- **ACCESSIBILITY.** The new Clausius heat pumps with propane also incorporate our popular Clausius top-hinged opening system (patented system), allowing easy access to all components inside the heat pump.

- **CONNECTION WITH PHOTOVOLTAIC INSTALLATIONS,** enabling the management of solar energy surplus, control of the power produced by the heat pump, control of periods with different electricity rates, and compatibility with SmartGrid systems.

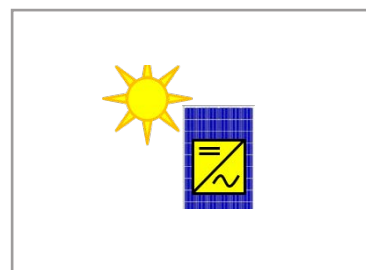



CLASSIC CONFIGURATION

- Power ranges from 1 to 8 kW / 3 to 15 kW / 5 to 25 kW
- COPs 4.5 / 4.8 / 4.9 respectively, according to EN14511
- EERs 4.7 / 5.3 / 5.6 respectively, according to EN14511
- Single-phase or three-phase power supply (not for 1-8 kW)
- Propane refrigerant (R290)
- Ultrasonic flow meters for brine and heating circuits
- Measurement of glycol concentration
- Air detection in brine and heating circuits
- Measurement of the pressure in brine and heating circuits
- Integrated energy meters, COP, EER and SPFs
- Copeland “low noise” compressors, minimum noise level
- Electronic expansion valve
- Integrated class A variable-speed circulation pumps
- Integrated expansion vessels and safety valves
- Integrated 3-way valve for DHW (domestic hot water) production
- Equipped with a propane detector and a leakage control system for indoor installation (not for 1-8 kW)
- New control strategies adapted to propane
- Control with climate regulation
- Control of 2 climate zones
- Pool control
- Special programs, floor drying, air venting, etc
- Maximum power limitation via software

Integrated flow meters and energy meters.

Minimum propane charge per kW produced.

The highest COP on the market with inverter technology since 2015.



CUSTOM CONFIGURATION

- Option to integrate a desuperheater for simultaneous DHW or pool production along with heating or cooling (not for 1-8 kW)
- Option to integrate a passive cooling production system
- Optional control with “Clausius Advance Control”



MODELS IN THREE POWER RANGES, 1-8 KW, 3-15 KW AND 5-25 KW

| | |
|----------|---|
| H | Heating |
| HC | Heating and active cooling |
| H PC | Heating and passive cooling |
| HC PC | Heating, active cooling and passive cooling |
| H DS | Heating and desuperheater (not for 1-8) |
| HC DS | Heating, active cooling and desuperheater (not for 1-8 kW) |
| H PC DS | Heating, passive cooling and desuperheater (not for 1-8 kW) |
| HC PC DS | Heating, active cooling, passive cooling and desuperheater (not for 1-8 kW) |



ELITE CONFIGURATION

- AISI 316 stainless steel DHW tank
- DHW production system up to 70 °C
- Power ranges from 1 to 8 kW / 3 to 15 kW / 5 to 25 kW
- COPs 4.5 / 4.8 / 4.9 respectively, according to EN14511
- EERs 4.7 / 5.3 / 5.6 respectively, according to EN14511
- Single-phase or three-phase power supply (not for 1-8 kW)
- Propane refrigerant (R290)
- Ultrasonic flow meters for brine and heating circuits
- Measurement of glycol concentration
- Air detection in brine and heating circuits
- Measurement of the pressure in brine and heating circuits
- Integrated energy meters, COP, EER and SPFs
- Copeland “low noise” compressors, minimum noise level
- Electronic expansion valve
- Integrated class A variable-speed circulation pumps
- Integrated expansion vessels and safety valves
- Equipped with a propane detector and a leakage control system for indoor installation (not for 1-8 kW)
- New control strategies adapted to propane
- Control with climate regulation
- Control of 2 climate zones
- Pool control
- Special programs, floor drying, air venting, etc
- Maximum power limitation via software
- Cascade connection capability of up to 6 units
- Individually tested on a test bench

Integrated flow meters and energy meters.

Minimum propane charge per kW produced.

DHW up to 65 °C without electric heaters.



CUSTOMISED CONFIGURATION

- Option to integrate a passive cooling production system
- Optional control with “Clausius Advance Control”



MODELS IN THREE POWER RANGES, 1-8 KW, 3-15 KW AND 5-25 KW

| | |
|-------|--|
| H | Heating and DHW production with a built-in tank |
| HC | Heating, DHW production with a built-in tank and active cooling |
| H PC | Heating, DHW production with a built-in tank and passive cooling |
| HC PC | Heating, DHW production with a built-in tank, active and passive cooling |

TECHNICAL SPECIFICATIONS

| | | H 1-8 (classic/elite) | HC 1-8 (classic/elite) | H 3-15 (classic/elite) | HC 3-15 (classic/elite) | H 5-25 (classic/elite) | HC 5-25 (classic/elite) |
|-----------------------------|---------------------------------|---|---------------------------|---------------------------|----------------------------|---------------------------|----------------------------|
| Applications | Heating and DHW | • | • | • | • | • | • |
| | Active cooling | | • | | • | | • |
| Optional applications | Passive cooling | • / • | • / • | • / • | • / • | • / • | • / • |
| | DHW and pool with desuperheater | - | - | • / • | • / • | • / • | • / • |
| Power | Heating (kW) | 1 - 8 | 1 - 8 | 3 - 15 | 3 - 15 | 5 - 25 | 5 - 25 |
| | Active cooling (kW) | | 1.5 - 9 | | 4 - 16 | | 5 - 27.5 |
| | Electrical consumption (kW) | 0.4 - 3.8 | 0.4 - 3.8 | 0.5 - 5.2 | 0.5 - 5.2 | 1.0 - 10.4 | 1.0 - 10.4 |
| Power supply | 230 V 1/N/PE ⁻ | • | • | • | • | • | • |
| | 400 V 3/N/PE ⁻ | - | - | • | • | • | • |
| Performance | COP ¹ | 4.5 | 4.5 | 4.8 | 4.8 | 4.9 | 4.9 |
| | EER ¹ | | 4.7 | | 5.3 | | 5.6 |
| DHW Tank | | External / Integrated | External / Integrated | External / Integrated | External / Integrated | External / Integrated | External / Integrated |
| Refrigerant | Type | Propane (R290) | | | | | |
| | Load (g) | 150 | 150 | 350 | 350 | 480 | 480 |
| Flow | Brine Min / Max (l/h) | 400 / 2200 | | 700 / 3600 | | 1200 / 6000 | |
| | Heating Min / Max (l/h) | 300 / 1500 | | 500 / 2600 | | 860 / 4300 | |
| Temperature | Min / Max (°C) | Brine = -15 / +20 | | | Heating = +25 / +70 | | |
| Maximum pressure drop (kPa) | Brine/Heating | 20 / 15 | | 33 / 20 | | 33 / 20 | |
| Dimensions | Height x Width x Depth (mm) | Classic 1040 x 600 x 800 / Elite 1878 x 600 x 800 | | | | | |
| Hydraulic connections | Brine and heating | 1" | | | | | |
| | DHW | 3/4" | | | | | |
| Weight | (kg) | 147 / 227 | 158 / 238 | 163 / 243 | 174 / 254 | 168 / 248 | 179 / 259 |
| Sound level | (dB) | 42 | | | | | |

⁽¹⁾According to EN14511 and EN14825. Certification pending.



Energy labelling, product sheets and technical documentation according to Delegated Regulation (UE) N° 811/2013.

A+++



**HIGH POWER RANGE WITH PROPANE,
STRONG P & STRONG DOUBLE P**



CLAUSIUS PROPANE STRONG P 7-35, 12-55, 15-65, 15-75 & 20-95 TECHNOLOGY

- **HIGH POWER WITH PROPANE AS A REFRIGERANT AND INVERTER TECHNOLOGY.**

CLAUSIUS has developed a new range of **HIGH POWER** Ground Source Heat Pumps with propane as a refrigerant and inverter technology.

- The **STRONG** range comprises 5 models with power ranges from 7 to 35, 12 to 55, 15 to 65, 15 to 75 and 20 to 95 kW.

- The **STRONG DOUBLE** range comprises 3 models with power ranges from 12 to 115 kW, 15 to 150 and 20 to 190 kW.



INVERTER
7-35 kW
12-55 kW
15-65 kW
15-75 kW
20-95 kW

INVERTER
12-115 kW
15-150 kW
20-190 kW

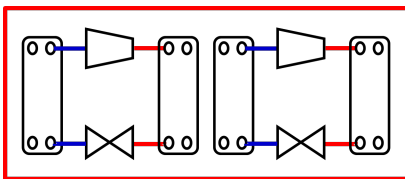

- **RELIABILITY WITH STRONG DOUBLE MODELS.** The **STRONG Double models** feature two fully independent refrigerant circuits, each equipped with its own inverter-driver system. This configuration allows each circuit to operate completely independently, ensuring continued operation even if one circuit is unavailable and therefore providing significantly increased system reliability.

- **MAXIMUM EFFICIENCY BY CONTROLLING THE OPTIMAL OPERATING POINT.** At any time, the control system establishes the optimal operational conditions considering the operation of both refrigerant circuits.



GAS SENSOR



- **SAFETY WITH PROPANE.** Propane is a flammable refrigerant (A3), so safety is a very important concern. Clausius heat pumps with propane are equipped with a propane detector and a leakage control system for indoor installation.

- **CUSTOMIZED CONFIGURATION.** All **STRONG** and **STRONG DOUBLE** models can be customized for each application being able to select between heating and DHW production, active cooling, and the integration of a desuperheater

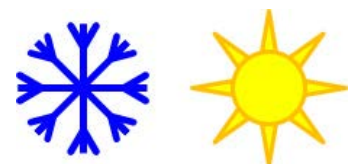

- **BUILT-IN DESUPERHEATER FOR HIGH TEMPERATURE DHW (OPTIONAL).** Independent DHW production circuit. New control system with flow regulation in the desuperheater for DHW production up to 60/65 °C.

CLAUSIUS PROPANE STRONG DOUBLE P 12-115, 15-150 & 20-190 TECHNOLOGY

- **READY TO USE WITH FLOW METERS IN BRINE AND HEATING CIRCUITS.** All **STRONG** and **STRONG DOUBLE** models are prepared to integrate ultrasonic flow meters, responding to a long-standing demand from our customers in recent years. On request, supplied by Clausius, flow meters enable:



- Accurate measurement of the thermal power extracted from the brine circuit and transferred to the heating and DHW circuits.
- Monitoring of the glycol concentration.
- Detection of air bubbles within the hydraulic circuits, enhancing system safety and operational reliability.



- **CASING FOR OUTDOOR / INDOOR INSTALLATION.** All **STRONG** models have sealed case for indoor / outdoor.

- **ACCESSIBILITY.** Lift opening system that allows an easy access to all components inside the unit (only classic and strong double models).



- **NEW CONTROL STRATEGIES.** More efficient, reliable and secure installations.

- **NEW INTERNET MANAGEMENT AND VISUALIZATION SYSTEM,** enabling remote access, preventive maintenance, and enhanced heat pump reliability.

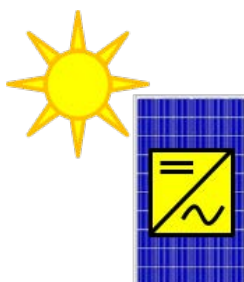

- **CONNECTION TO PHOTOVOLTAIC INSTALLATIONS.** Energy surplus management, control of the power produced by the heat pump, control of periods with different electricity rates and compatible with Smart Grid systems.

High power range with PROPANE, STRONG P

STRONG P 7-35, 12-55, 15-65, 15-75 & 20-95 OUTDOOR AND INDOOR CONFIGURATION



- Casing for outdoor / indoor installation
- Power ranges from 7 to 35 kW / 12 to 55 kW / 15 to 65 kW / 15 to 75 kW / 20 to 95 kW
- COPs 4.5 / 4.6 / 4.8 / 4.8 / 4.8, according to EN14511
- EERs 5.2 / 5.4 / 5.7 / 5.7 / 5.7 according to EN14511
- Three phases electrical power supply
- Propane refrigerant R290
- Measurement of the pressure in brine and heating circuits
- Integrated energy meters, COP, EER and SPFs
- Danfoss compressors
- Electronic expansion valves
- Built in pressure sensors in both brine and heating circuits
- Active cooling integrated
- New control strategies adapted to propane
- Swimming pool control
- Control of 5 mixing groups and 6 climate zones
- External passive cooling control
- Control of DHW production in two independent tanks
- Control with climate regulation
- Maximum power limitation via software
- Cascade connection capability of up to 6 units
- Individually tested on a test bench in our factory
- Ready for integration with electronic flow meters allowing the measurement glicol concentration and air bubble detection in both brine and heating circuits



WITH PROPANE

Casing for outdoor / indoor installation.



Available in tulip white or blue propane.

CUSTOMISED CONFIGURATION

- Built-in desuperheater for high temperature DHW production, optional



MODELS IN FIVE POWER RANGES, 7-35 KW, 12-55 KW, 15-65 KW, 15-75 KW AND 20-95 KW

| | |
|-------|---|
| H | Heating |
| HC | Heating & active cooling |
| H DS | Heating & desuperheater |
| HC DS | Heating, active cooling & desuperheater |

TECHNICAL SPECIFICATIONS STRONG 7-35

| | | H 7-35 | H 7 - 35 DS | HC 7-35 | HC 7 - 35 DS |
|-----------------------------|---|---------------------------------------|-------------|---------|--------------|
| Applications | Heating and DHW | • | • | • | • |
| | Active cooling | | | • | • |
| Optional application | High temperature DHW with desuperheater | | • | | • |
| External components control | Circulation pumps control | • | • | • | • |
| | DHW control | • | • | • | • |
| | External passive cooling control | • | • | • | • |
| | Swimming pool control | • | • | • | • |
| | Mixing groups control | • | • | • | • |
| | Electric heaters control | • | • | • | • |
| Power | Heating (kW) | 7-35 | 7-35 | 7-35 | 7-35 |
| | Active cooling (kW) | | | 8-36 | 8-36 |
| | Desuperheater (kW) (optional) | | 12 | | 12 |
| Electrical supply | 3 ph - 400 V | | | | |
| Electrical power | Maximum | 14 kW | | | |
| Performance | COP ⁽¹⁾ | 4.5 | 4.5 | 4.5 | 4.5 |
| | EER ⁽¹⁾ | | | 5.2 | 5.2 |
| | SCOP ⁽¹⁾ | 5.07 | 5.07 | 5.07 | 5.07 |
| Refrigerant | Type | R290 | | | |
| | Load (kg) | 1.8 | 1.8 | 1.8 | 1.8 |
| Flow | Brine Min / Max (l/h) | 1700 / 8300 | | | |
| | Heating Min / Max (l/h) | 1200 / 6000 | | | |
| Temperatures | Min / Max (°C) | Brine = -15 / +20 Heating = +25 / +65 | | | |
| Pressure Drop | Maximum (kPa) | Brine = 27 Heating = 19 | | | |
| Dimensions | Height x Width x Depth (mm) | 1600 x 1000 x 600 | | | |
| Connections size | Brine and heating | 2" | | | |
| | Desuperheater (optional) | 1 1/4" | | 1 1/4" | |
| Weight | (kg) | 213 | 221 | 215 | 233 |
| Sound level ⁽²⁾ | (dB) | 52 | | | |

⁽¹⁾According to EN14511 and EN14825. Certification pending.



Energy labelling, product sheets and technical documentation according to **Delegated Regulation (UE) N° 811/2013**

A+++

TECHNICAL SPECIFICATIONS STRONG 12-55

| | | H 12-55 | H 12-55 DS | HC 12-55 | HC 12-55 DS |
|-----------------------------|---|---------------------------------------|------------|--------------|-------------|
| Applications | Heating and DHW | • | • | • | • |
| | Active cooling | | | • | • |
| Optional application | High temperature DHW with desuperheater | | • | | • |
| External components control | Circulation pumps control | • | • | • | • |
| | DHW control | • | • | • | • |
| | External passive cooling control | • | • | • | • |
| | Swimming pool control | • | • | • | • |
| | Mixing groups control | • | • | • | • |
| | Electric heaters control | • | • | • | • |
| Power | Heating (kW) | 12-55 | 12-55 | 12-55 | 12-55 |
| | Active cooling (kW) | | | 14-58 | 14-58 |
| | Desuperheater (kW) (optional) | | 20 | | 20 |
| Electrical supply | 3 ph - 400 V | | | | |
| Electrical power | Maximum | 23 kW | | | |
| Performance | COP ⁽¹⁾ | 4.6 | 4.6 | 4.6 | 4.6 |
| | EER ⁽¹⁾ | | | 5.4 | 5.4 |
| | SCOP ⁽¹⁾ | 5.11 | 5.11 | 5.11 | 5.11 |
| Refrigerant | Type | R290 | | | |
| | Load (kg) | 2.0 | 2.0 | 2.0 | 2.0 |
| Flow | Brine Min / Max (l/h) | 2900 / 13100 | | | |
| | Heating Min / Max (l/h) | 2100 / 9500 | | | |
| Temperatures | Min / Max (°C) | Brine = -15 / +20 Heating = +25 / +65 | | | |
| Pressure Drop | Maximum (kPa) | Brine = 41 | | Heating = 40 | |
| Dimensions | Height x Width x Depth (mm) | 1600 x 1000 x 600 | | | |
| Connections size | Brine and heating | 2" | | | |
| | Desuperheater (optional) | 1 1/4" | | 1 1/4" | |
| Weight | (kg) | 238 | 246 | 240 | 258 |
| Sound level ⁽²⁾ | (dB) | 52 | | | |

⁽¹⁾ According to EN14511 and EN14825. Certification pending.



Energy labelling, product sheets and technical documentation according to **Delegated Regulation (UE) N° 811/2013**

A+++

TECHNICAL SPECIFICATIONS STRONG 15-65

| | | H 15-65 | H 15-65 DS | HC 15-65 | HC 15-65 DS |
|-----------------------------|---|---------------------------------------|------------|----------|-------------|
| Applications | Heating and DHW | • | • | • | • |
| | Active cooling | | | • | • |
| Optional application | High temperature DHW with desuperheater | | • | | • |
| External components control | Circulation pumps control | • | • | • | • |
| | DHW control | • | • | • | • |
| | External passive cooling control | • | • | • | • |
| | Swimming pool control | • | • | • | • |
| | Mixing groups control | • | • | • | • |
| | Electric heaters control | • | • | • | • |
| Power | Heating (kW) | 15-65 | 15-65 | 15-65 | 15-65 |
| | Active cooling (kW) | | | 18-70 | 18-70 |
| | Desuperheater (kW) (optional) | | 22 | | 22 |
| Electrical supply | 3 ph - 400 V | | | | |
| Electrical power | Maximum | 27 kW | | | |
| Performance | COP ⁽¹⁾ | 4.8 | 4.8 | 4.8 | 4.8 |
| | EER ⁽¹⁾ | | | 5.7 | 5.7 |
| | SCOP ⁽¹⁾ | 5.3 | 5.3 | 5.3 | 5.3 |
| Refrigerant | Type | R290 | | | |
| | Load (kg) | 2.35 | 2.35 | 2.35 | 2.35 |
| Flow | Brine Min / Max (l/h) | 3600 / 15700 | | | |
| | Heating Min / Max (l/h) | 2600 / 11300 | | | |
| Temperatures | Min / Max (°C) | Brine = -15 / +20 Heating = +25 / +65 | | | |
| Pressure Drop | Maximum (kPa) | Brine = 44 Heating = 34 | | | |
| Dimensions | Height x Width x Depth (mm) | 1600 x 1000 x 600 | | | |
| Connections size | Brine and heating | 2" | | | |
| | Desuperheater (optional) | 1 1/4" | | | |
| Weight | (kg) | 247 | 256 | 262 | 270 |
| Sound level ⁽²⁾ | (dB) | 52 | | | |

⁽¹⁾ According to EN14511 and EN14825. Certification pending.

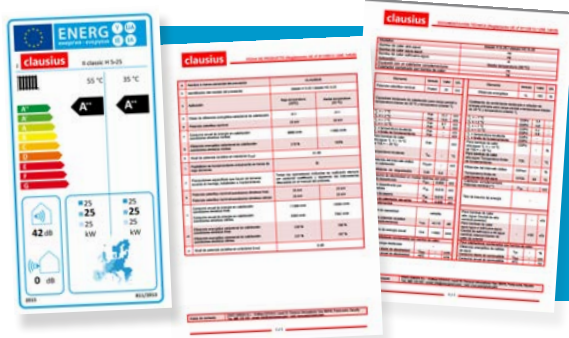

A+++

Energy labelling, product sheets and technical documentation according to **Delegated Regulation (UE) N° 811/2013**

TECHNICAL SPECIFICATIONS STRONG 15-75

| | | H 15-75 | H 15-75 DS | HC 15-75 | HC 15-75 DS |
|-----------------------------|---|---------------------------------------|------------|--------------|-------------|
| Applications | Heating and DHW | • | • | • | • |
| | Active cooling | | | • | • |
| Optional application | High temperature DHW with desuperheater | | • | | • |
| External components control | Circulation pumps control | • | • | • | • |
| | DHW control | • | • | • | • |
| | External passive cooling control | • | • | • | • |
| | Swimming pool control | • | • | • | • |
| | Mixing groups control | • | • | • | • |
| | Electric heaters control | • | • | • | • |
| Power | Heating (kW) | 15-75 | 15-75 | 15-75 | 15-75 |
| | Active cooling (kW) | | | 18-80 | 18-80 |
| | Desuperheater (kW) (optional) | | 25 | | 25 |
| Electrical supply | 3 ph - 400 V | | | | |
| Electrical power | Maximum | 28 kW | | | |
| Performance | COP ⁽¹⁾ | 4.8 | 4.8 | 4.8 | 4.8 |
| | EER ⁽¹⁾ | | | 5.7 | 5.7 |
| | SCOP ⁽¹⁾ | 5.3 | 5.3 | 5.3 | 5.3 |
| Refrigerant | Type / Compressor oil charge by volume / mass | POE / 3.3 l / 3.75 kg | | | |
| | Propane (R290) charge (kg) | 2.35 | 2.35 | 2.35 | 2.35 |
| Flow | Brine Min / Max (l/h) | 3600 / 18100 | | | |
| | Heating Min / Max (l/h) | 2600 / 13000 | | | |
| Temperatures | Min / Max (°C) | Brine = -15 / +20 Heating = +25 / +65 | | | |
| Pressure Drop | Maximum (kPa) | Brine = 44 | | Heating = 34 | |
| Dimensions | Height x Width x Depth (mm) | 1600 x 1000 x 600 | | | |
| Connections size | Brine and heating | 2" | | | |
| | Desuperheater (optional) | 1 1/4" | | 1 1/4" | |
| Weight | (kg) | 247 | 256 | 262 | 270 |
| Sound level ⁽²⁾ | (dB) | 52 | | | |

⁽¹⁾ According to EN14511 and EN14825. Certification pending.

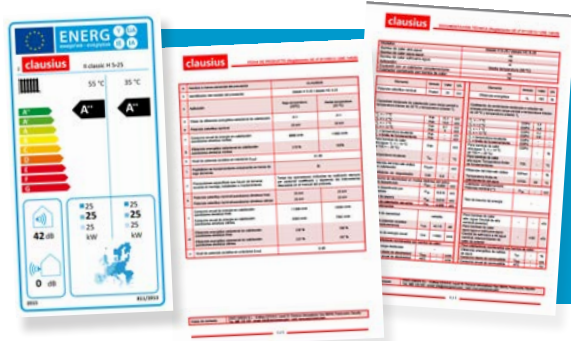

A+++

Energy labelling, product sheets and technical documentation according to **Delegated Regulation (UE) N° 811/2013**

TECHNICAL SPECIFICATIONS STRONG 20-95

| | | H 20-95 | H 20-95 DS | HC 20-95 | HC 20-95 DS |
|-----------------------------|---|---------------------------------------|------------|--------------|-------------|
| Applications | Heating and DHW | • | • | • | • |
| | Active cooling | | | • | • |
| Optional application | High temperature DHW with desuperheater | | • | | • |
| External components control | Circulation pumps control | • | • | • | • |
| | DHW control | • | • | • | • |
| | External passive cooling control | • | • | • | • |
| | Swimming pool control | • | • | • | • |
| | Mixing groups control | • | • | • | • |
| | Electric heaters control | • | • | • | • |
| Power | Heating (kW) | 20-95 | 20-95 | 20-95 | 20-95 |
| | Active cooling (kW) | | | 23-100 | 23-100 |
| | Desuperheater (kW) (optional) | | 33 | | 33 |
| Electrical supply | 3 ph - 400 V | | | | |
| Electrical power | Maximum | 31 kW | | | |
| Performance | COP ⁽¹⁾ | 4.8 | 4.8 | 4.8 | 4.8 |
| | EER ⁽¹⁾ | | | 5.7 | 5.7 |
| | SCOP ⁽¹⁾ | 5.1 | 5.1 | 5.1 | 5.1 |
| Refrigerant | Type / Compressor oil charge by volume / mass | POE / 3.3 l / 3.75 kg | | | |
| | Propane (R290) charge (kg) | 2.9 | 2.9 | 2.9 | 2.9 |
| Flow | Brine Min / Max (l/h) | 4800 / 23000 | | | |
| | Heating Min / Max (l/h) | 3400 / 16400 | | | |
| Temperatures | Min / Max (°C) | Brine = -15 / +20 Heating = +25 / +65 | | | |
| Pressure Drop | Maximum (kPa) | Brine = 53 | | Heating = 33 | |
| Dimensions | Height x Width x Depth (mm) | 1600 x 1000 x 600 | | | |
| Connections size | Brine and heating | 2" | | | |
| | Desuperheater (optional) | 1 1/4" | | 1 1/4" | |
| Weight | (kg) | 264 | 273 | 279 | 287 |
| Sound level ⁽²⁾ | (dB) | 52 | | | |

⁽¹⁾ According to EN14511 and EN14825. Certification pending.



Energy labelling, product sheets and technical documentation according to **Delegated Regulation (UE) N° 811/2013**

A+++

STRONG DOUBLE P 12-110, 15-150 & 20-190 CONFIGURATION



- Power ranges from 12 to 115 kW and 15 to 150 kW
- COPs 4.6 / 4.8 / 4.8, according to EN14511
- EERs 5.4 / 5.7 / 5.7 according to EN14511
- Three phases electrical power supply
- Propane refrigerant R290
- Measurement of the pressure in brine and heating circuits
- Integrated energy meters, COP, EER and SPFs
- Danfoss compressors
- Electronic expansion valves
- Built in pressure sensors in both brine and heating circuits
- Active cooling integrated
- New control strategies adapted to propane
- Swimming pool control
- Control of 5 mixing groups and 6 climate zones
- External passive cooling control
- Control of DHW production in two independent tanks
- Control with climate regulation
- Maximum power limitation via software
- Cascade connection capability of up to 6 units
- Individually tested on a test bench in our factory
- Ready to use with electronic flow meters which allow the measurement glycol concentration and air bubble detection in the brine and heating circuits



High power with propane as a refrigerant and inverter technology

Two totally independent refrigerant circuits, double reliability.



CUSTOMISED CONFIGURATION

- Built-in desuperheater for high temperature DHW production, optional



MODELS IN THREE POWER RANGES, 12-115 KW, 15-150 KW AND 20-190 KW

| | |
|-------|---|
| H | Heating |
| HC | Heating & active cooling |
| H DS | Heating & desuperheater |
| HC DS | Heating, active cooling & desuperheater |

TECHNICAL SPECIFICATIONS STRONG DOUBLE P 12-115

| | | H 12-115 | H 12-115 DS | HC 12-115 | HC 12-115 DS |
|-----------------------------|---|---------------------------------------|-------------|-----------|--------------|
| Applications | Heating and DHW | • | • | • | • |
| | Active cooling | | | • | • |
| Optional application | High temperature DHW with desuperheater | | • | | • |
| External components control | Circulation pumps control | • | • | • | • |
| | DHW control | • | • | • | • |
| | External passive cooling control | • | • | • | • |
| | Swimming pool control | • | • | • | • |
| | Mixing groups control | • | • | • | • |
| | Electric heaters control | • | • | • | • |
| Power | Heating (kW) | 12-115 | 12-115 | 12-115 | 12-115 |
| | Active cooling (kW) | | | 14-116 | 14-116 |
| | Desuperheater (kW) (optional) | | 40 | | 40 |
| Electrical supply | 3 ph - 400 V | | | | |
| Electrical power | Maximum | 46 kW | | | |
| Performance | COP ⁽¹⁾ | 4.6 | 4.6 | 4.6 | 4.6 |
| | EER ⁽¹⁾ | | | 5.4 | 5.4 |
| | SCOP ⁽¹⁾ | 5.11 | 5.11 | 5.11 | 5.11 |
| Refrigerant | Type / Compressor oil charge by volume / mass | POE / 3.3 l / 3.75 kg | | | |
| | Propane (R290) total charge (kg) | 2.6 | 2.6 | 2.6 | 2.6 |
| Flow | Brine Min / Max (l/h) | 2900 / 26300 | | | |
| | Heating Min / Max (l/h) | 2100 / 19000 | | | |
| Temperatures | Min / Max (°C) | Brine = -15 / +20 Heating = +25 / +65 | | | |
| Pressure Drop | Maximum (kPa) | Brine = 42 Heating = 36 | | | |
| Dimensions | Height x Width x Depth (mm) | 1490 x 1640 x 760 | | | |
| Connections size | Brine and heating | 3" | | | |
| | Desuperheater (optional) | 1 1/4" | | 1 1/4" | |
| Weight | (kg) | 452 | 461 | 467 | 475 |
| Sound level ⁽²⁾ | (dB) | 65 | | | |

⁽¹⁾ According to EN14511 and EN14825. Certification pending.

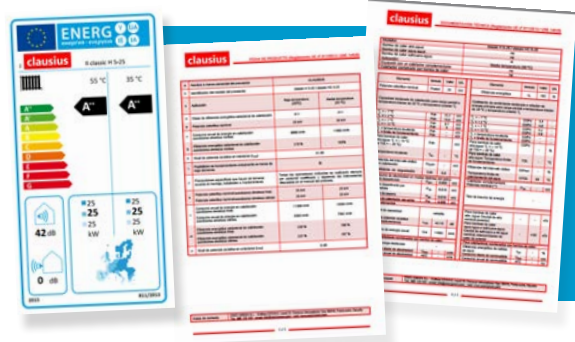

Energy labelling, product sheets and technical documentation according to **Delegated Regulation (UE) N° 811/2013**

A+++

TECHNICAL SPECIFICATIONS STRONG DOUBLE P 15-150

| | | H 15-150 | H 15-150 DS | HC 15-150 | HC 15-150 DS |
|-----------------------------|---|---------------------------------------|-------------|-----------|--------------|
| Applications | Heating and DHW | • | • | • | • |
| | Active cooling | | | • | • |
| Optional application | High temperature DHW with desuperheater | | • | | • |
| External components control | Circulation pumps control | • | • | • | • |
| | DHW control | • | • | • | • |
| | External passive cooling control | • | • | • | • |
| | Swimming pool control | • | • | • | • |
| | Mixing groups control | • | • | • | • |
| | Electric heaters control | • | • | • | • |
| Power | Heating (kW) | 15-150 | 15-150 | 15-150 | 15-150 |
| | Active cooling (kW) | | | 18-160 | 18-160 |
| | Desuperheater (kW) (optional) | | 50 | | 50 |
| Electrical supply | 3 ph - 400 V | | | | |
| Electrical power | Maximum | 56 kW | | | |
| Performance | COP ⁽¹⁾ | 4.8 | 4.8 | 4.8 | 4.8 |
| | EER ⁽¹⁾ | | | 5.7 | 5.7 |
| | SCOP ⁽¹⁾ | 5.15 | 5.15 | 5.15 | 5.15 |
| Refrigerant | Type / Compressor oil charge by volume / mass | POE / 3.3 l / 3.75 kg | | | |
| | Propane (R290) total charge (kg) | 4.7 | 4.7 | 4.7 | 4.7 |
| Flow | Brine Min / Max (l/h) | 3600 / 36200 | | | |
| | Heating Min / Max (l/h) | 2600 / 25800 | | | |
| Temperatures | Min / Max (°C) | Brine = -15 / +20 Heating = +25 / +65 | | | |
| Pressure Drop | Maximum (kPa) | Brine = 45 Heating = 35 | | | |
| Dimensions | Height x Width x Depth (mm) | 1490 x 1640 x 760 | | | |
| Connections size | Brine and heating | 3" | | | |
| | Desuperheater (optional) | 1 1/4" | | 1 1/4" | |
| Weight | (kg) | 469 | 474 | 485 | 490 |
| Sound level ⁽²⁾ | (dB) | 68 | | | |

⁽¹⁾ According to EN14511 and EN14825. Certification pending.

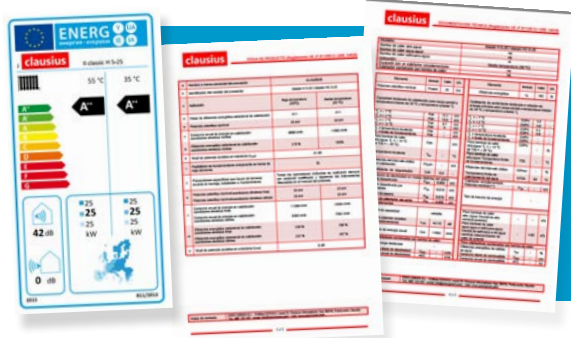

Energy labelling, product sheets and technical documentation according to **Delegated Regulation (UE) N° 811/2013**

A+++

TECHNICAL SPECIFICATIONS STRONG DOUBLE P 20-190

| | | H 20-190 | H 20-190 DS | HC 20-190 | HC 20-190 DS |
|-----------------------------|---|---------------------------------------|-------------|-----------|--------------|
| Applications | Heating and DHW | • | • | • | • |
| | Active cooling | | | • | • |
| Optional application | High temperature DHW with desuperheater | | • | | • |
| External components control | Circulation pumps control | • | • | • | • |
| | DHW control | • | • | • | • |
| | External passive cooling control | • | • | • | • |
| | Swimming pool control | • | • | • | • |
| | Mixing groups control | • | • | • | • |
| | Electric heaters control | • | • | • | • |
| Power | Heating (kW) | 20-190 | 20-190 | 20-190 | 15-150 |
| | Active cooling (kW) | | | 23-200 | 23-200 |
| | Desuperheater (kW) (optional) | | 66 | | 66 |
| Electrical supply | 3 ph - 400 V | | | | |
| Electrical power | Maximum | 66 kW | | | |
| Performance | COP ⁽¹⁾ | 4.8 | 4.8 | 4.8 | 4.8 |
| | EER ⁽¹⁾ | | | 5.7 | 5.7 |
| | SCOP ⁽¹⁾ | 5.1 | 5.1 | 5.1 | 5.1 |
| Refrigerant | Type / Compressor oil charge by volume / mass | POE / 3.3 l / 3.75 kg | | | |
| | Propane (R290) total charge (kg) | 6.0 | 6.0 | 6.0 | 6.0 |
| Flow | Brine Min / Max (l/h) | 4800 / 46000 | | | |
| | Heating Min / Max (l/h) | 3400 / 32700 | | | |
| Temperatures | Min / Max (°C) | Brine = -15 / +20 Heating = +25 / +65 | | | |
| Pressure Drop | Maximum (kPa) | Brine = 55 Heating = 30 | | | |
| Dimensions | Height x Width x Depth (mm) | 1490 x 1640 x 760 | | | |
| Connections size | Brine and heating | 3" | | | |
| | Desuperheater (optional) | 1 1/4" | | 1 1/4" | |
| Weight | (kg) | 501 | 510 | 516 | 524 |
| Sound level ⁽²⁾ | (dB) | 68 | | | |

⁽¹⁾ According to EN14511 and EN14825. Certification pending.

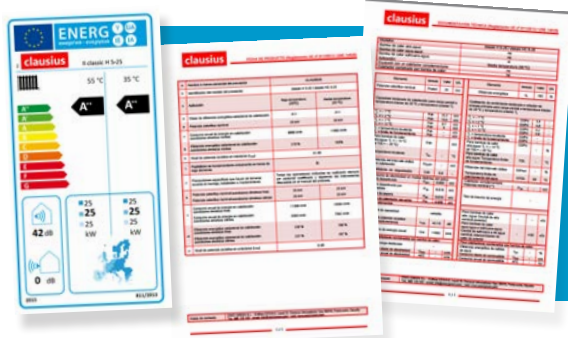

Energy labelling, product sheets and technical documentation according to **Delegated Regulation (UE) N° 811/2013**

A+++

HIGH TEMPERATURE RANGE, HT



CLAUSIUS HIGH TEMPERATURE HEAT PUMPS

CLAUSIUS high temperature heat pumps are specially designed for the use of heat sources at high temperatures, up to 45 °C (evaporating temperature up to 40 °C), and for delivering heat at very high temperatures, up to 80 °C (condensing temperature up to 85 °C). These heat pumps can cover operating ranges between source and sink temperatures higher than those of traditional heat pumps. These special features allow the use of heat pumps in new applications where standard heat pumps cannot be used.

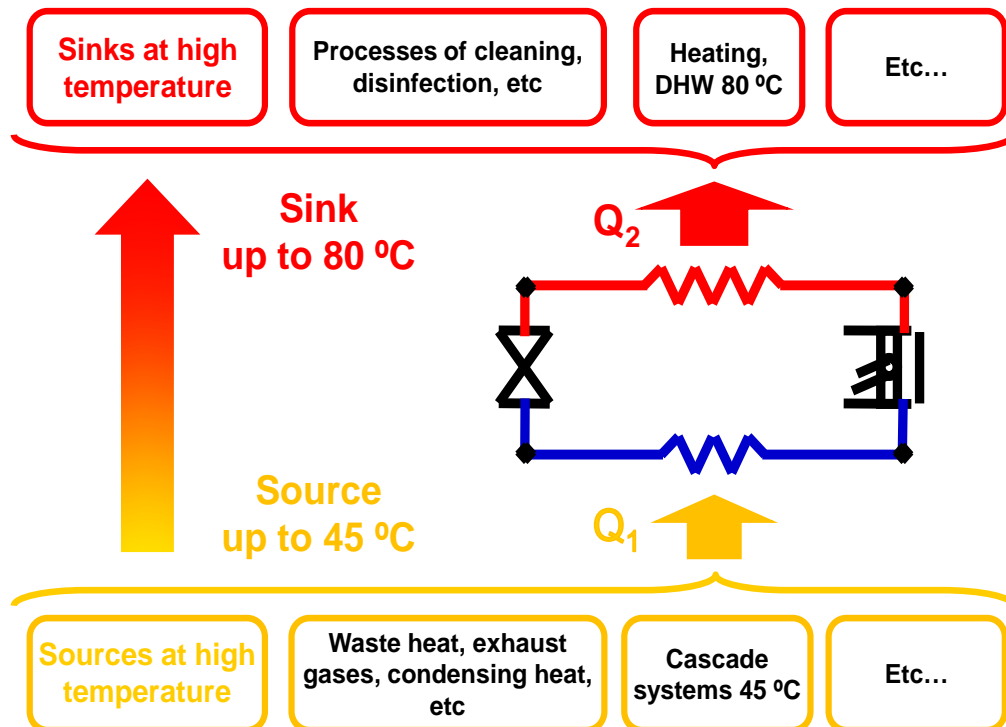

CLAUSIUS HT heat pumps applications.

Due to their wide operating range, CLAUSIUS HT heat pumps can be used, among others, for the following applications:

- Applications with high source temperatures (up to 40 °C), such as the use of geothermal resources at high temperatures, springs or ground water, etc.
- Applications for the recovery of waste heat such as, machinery cooling processes, exhaust gases from combustion processes, condensing heat from refrigerating installations, etc.
- Production of domestic hot water at high temperature.
- Applications where heat at high temperature is required such as heating systems with radiators, district heating, washing, cleaning or disinfection processes, etc.

Cascade systems with CLAUSIUS HT heat pumps

CLAUSIUS HT heat pumps open the door to new configuration possibilities for heating installations in buildings based solely on the use of heat pumps.

Cascade configurations combining Standard and High Temperature heat pumps overcome the main drawback of standard heat pump installations by allowing the production of high temperature hot water for both DHW production and heating systems requiring high temperatures.

CLAUSIUS High Temperature Heat Pumps allow the direct replacement of building boilers without the need to make changes to the buffer tanks or the distribution and emission systems. These cascade installations are compatible with high temperature radiators due to their ability to produce hot water at high temperatures (up to 80 °C).

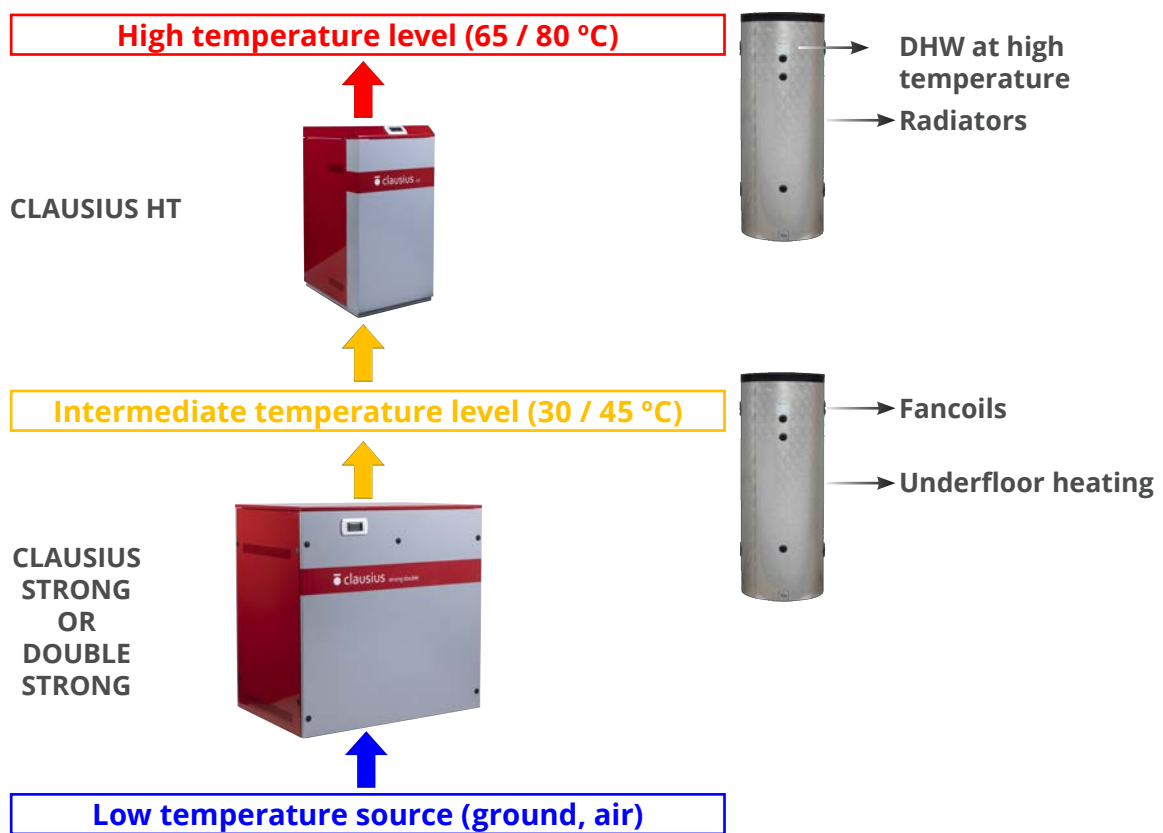

For special applications, contact CLAUSIUS

CLAUSIUS high temperature heat pumps are customised to each application, both in its configuration and in the control system. Given the wide range of operating conditions that may be required in high temperature heat pump applications, we recommend contacting CLAUSIUS for advice on the sizing and selection of the required heat pump model.

In addition to the standard models and for special applications, CLAUSIUS can design and manufacture tailored solutions with high temperature heat pumps. In these cases, the control system will be adapted and the heat pump will be tested on a test bench according to the specific requirements for each application. CLAUSIUS will provide all the technical documentation for these customised heat pumps.

CLAUSIUS HT technology and configuration

CLAUSIUS HT heat pumps were developed and are manufactured based on the use of high quality components:

- R134a refrigerant.
- Copeland scroll compressors specially designed for high temperature applications.
- Alfa Laval heat exchangers.
- Electronic expansion valve.
- Control system specially designed by CLAUSIUS and adapted to each application.

Standard models are manufactured in STRONG or STRONG DOUBLE model casings depending on the heating power.

Standard models

 *High temperature applications with heating temperatures up to 80 °C and source temperatures up to 45 °C.*

| STANDARD MODELS | Power 40/37 and 80/75 [kW]* | Power 0/-3 and 30/35 [kW]** | CASING |
|-----------------|-----------------------------|-----------------------------|---------------|
| Clausius HT 40 | 40 | 16 | Strong |
| Clausius HT 50 | 50 | 22 | Strong |
| Clausius HT 75 | 75 | 32 | Strong |
| Clausius HT 100 | 100 | 42 | Strong Double |
| Clausius HT 125 | 125 | 52 | Strong Double |
| Clausius HT 150 | 150 | 65 | Strong Double |

*Heating power with source 40/37 °C and sink 80/75 °C

**Heating power 0/-3 °C and 30/35 °C, according to EN 14511.



CLAUSIUS AIR AND HYBRID SYSTEMS



CLAUSIUS AIR SYSTEM

Heating and cooling systems with ground source heat pumps have many advantages over the systems with air source heat pumps and are more efficient and reliable. However, in some cases, it may not be possible to install a ground collector due to space limitations or other types of legislative restrictions, due to which, and only in these cases, CLAUSIUS recommends the use of air source heat pumps.

The CLAUSIUS Air System is based on keeping all the advantages of the ground source systems, replacing only the ground collector by a simple, efficient, reliable, robust and long-lasting air source unit.

CLAUSIUS Air System uses the same CLAUSIUS ground source heat pumps along with an external air unit (CLAUSIUS Air Source), specially designed and approved and validated by CLAUSIUS. This system extracts the energy available in the air and supplies it to the heat pump.

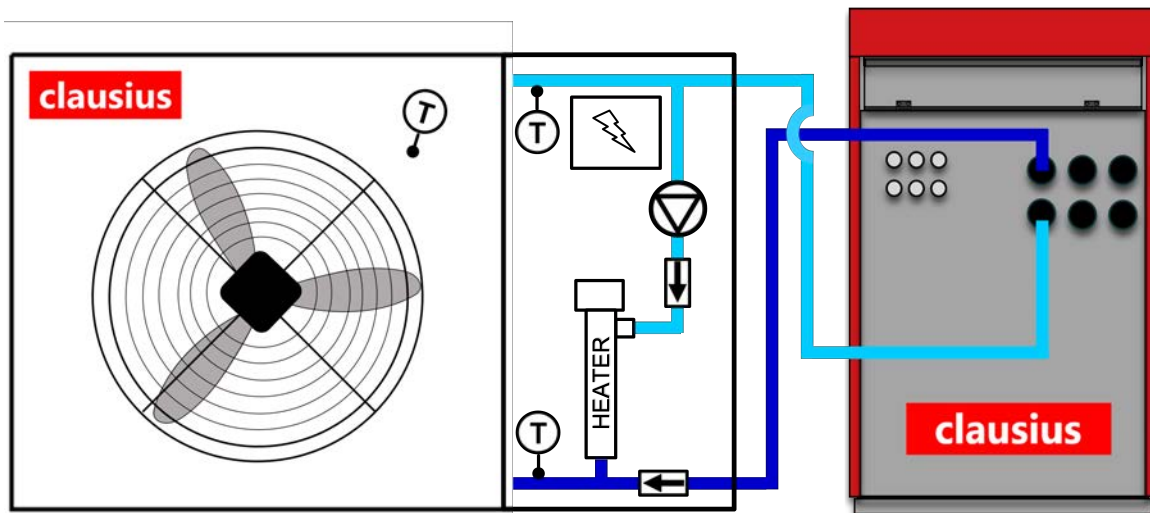

Simplified diagram, CLAUSIUS air System

The outdoor CLAUSIUS Air Unit transfers the energy captured from the air to the heat pump through a closed circuit with glycol circulation, just like in the ground source systems. This makes the CLAUSIUS Air System simple and reliable, since it does not require refrigerant circulation between the outdoor air unit and the indoor heat pump, which would require installation by highly qualified personnel and would reduce the reliability of the system due to possible high-pressure refrigerant leaks in the pipes.

Furthermore, compared to systems with compact air source heat pumps, in which their components are exposed to outdoor conditions, the CLAUSIUS air system has the advantage that only the air unit is located outside while all the remaining components are located indoor, protected from weather conditions, enhancing reliability and extending the system's lifespan.

CLAUSIUS HYBRID SYSTEM

CLAUSIUS ground source heat pumps can be used in hybrid geothermal-aerothermal systems, in which both a ground collector and an air collector are used simultaneously and integrated in the same installation. Hybrid systems allow to obtain the advantages of both energy collection systems and avoid their major drawbacks, which are the low efficiency of the air systems at low outside temperatures and the cost of the ground collectors.

CLAUSIUS heat pumps incorporate a specific control for hybrid systems. The control system choose the operating conditions that provide maximum possible energy efficiency by an optimum glycol flow distribution between the ground and the air collectors, obtaining the maximum efficiency of the heating and cooling system at all times.

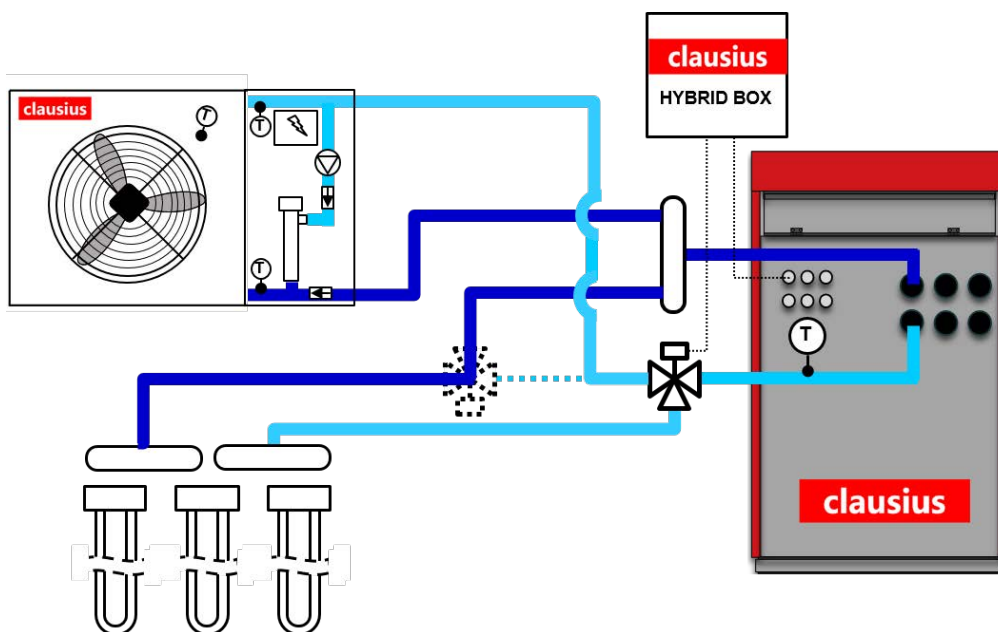

Simplified scheme, CLAUSIUS Hybrid System

Hybrid systems with ground recharging

CLAUSIUS hybrid systems allow to recharge energy in the ground when the outside temperature is high and heating the house is not required. This is achieved by transferring the thermal energy captured with the air system and dissipating it in the ground through the ground collector system.

Recharging the ground is carried out at a very low cost and allows to use it as an energy storage system. The energy stored is subsequently recovered by the ground collector system to reuse it to heat the house through the heating system.

CLAUSIUS AIR UNITS

CLAUSIUS Air Units used in the CLAUSIUS Air and Hybrid Systems have been specially designed by CLAUSIUS in collaboration with a well-known manufacturer. All CLAUSIUS Air Units are equipped with EC fans. The heat pump controls the rotation speed of the fans.

Clausius air units also include a diffusers specially designed to achieve high airflows at the lowest pressure range, which allows noise reduction of up to 4.5 dB (A), lower operational cost, energy optimization and compliance with the ErP Directive 2009/125/EC.

The CLAUSIUS range of Air Units covers the needs of all CLAUSIUS heat pumps, from domestic to high power. All CLAUSIUS Air Units incorporate the unique CLAUSIUS Defrosting system specially designed by CLAUSIUS, which increases the overall efficiency of the CLAUSIUS air and hybrid systems.



Air Unit 12



Air Unit 20



Air Unit 40 - 60 - 80 and 120

CLAUSIUS defrost system

CLAUSIUS Air Units are equipped with the exclusive defrosting system “Local Defrosting System” specially designed and validated by CLAUSIUS, which consists of heating the glycol inside the Air Unit and its recirculation only inside the tubes, thus preventing its circulation through the connection loop between the Air Unit and the heat pump. This feature allows to reduce the defrosting times and to increase considerably the efficiency of the air system.

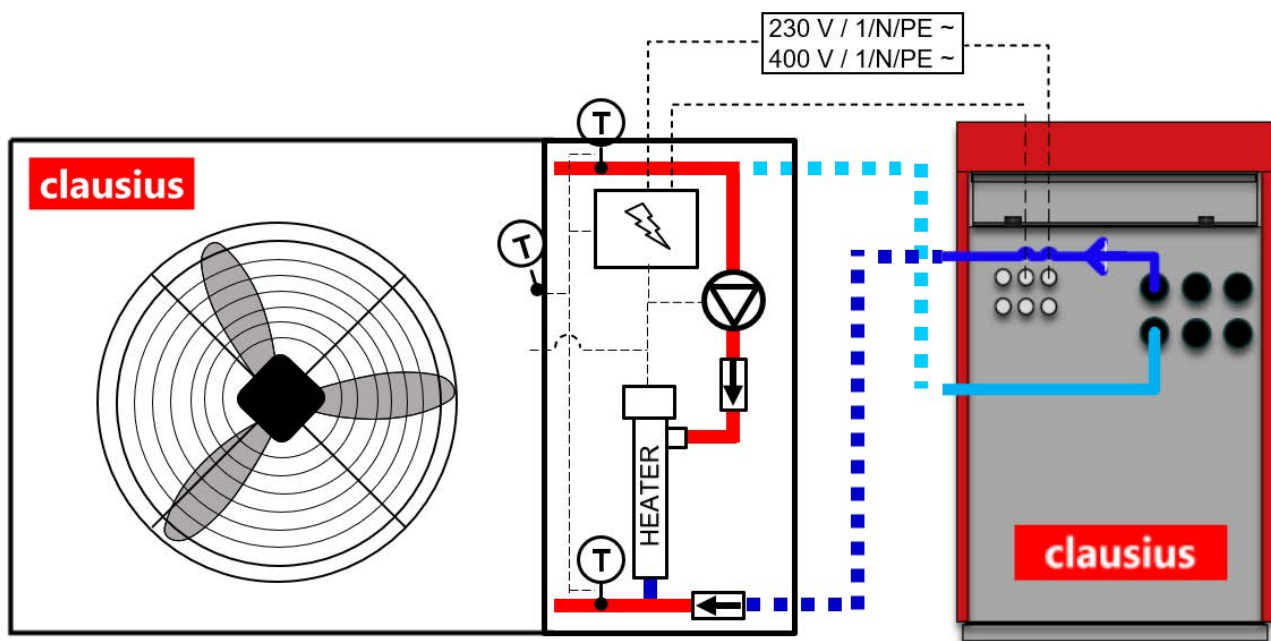

This exclusive CLAUSIUS defrosting system provides the following advantages over other traditional systems.

- Heat is supplied from inside the tubes, which means faster and more efficient defrosting, minimising heat losses to the environment.
- The heating and recirculation of the glycol is carried out only inside the air unit, thus avoiding its circulation through the connection circuit between the Air Unit and the heat pump. This feature avoids significant thermal losses, as well as expansions due to temperature variations in the elements and connections of the circuit, which provides the system greater reliability and efficiency than systems in which the glycol is heated in the heat pump itself.
- The defrost system is installed in the Air Units and tested by CLAUSIUS.

CLAUSIUS Air Units technical specifications

| MODEL | AIR UNIT 12 | AIR UNIT 20 | AIR UNIT 40 | AIR UNIT 60 | AIR UNIT 80 | AIR UNIT 120 |
|--|---|-----------------------|--------------------|---------------------------|--------------------|--------------------|
| Power (kW) | 11.04 | 18.01 | 43.20 | 61.50 | 79.30 | 114.80 |
| Air flow (m ³ /h) | 12000 | 14000 | 16100 | 30800 | 32700 | 48200 |
| Inlet air temperature (°C) | 7.0 | 7.0 | 7.0 | 7.0 | 7.0 | 7.0 |
| Outlet air temperature (°C) | 4.4 | 3.4 | -0.6 | 1.3 | 0.1 | 0.2 |
| Glycol flow inside tubes (m ³ /h) | 3.3 | 5.4 | 12.86 | 18.31 | 23.61 | 34.18 |
| Inlet glycol temperature (°C) | -3.0 | -3.0 | -3.0 | -3.0 | -3.0 | -3.0 |
| Outlet glycol temperature (°C) | 0.0 | 0.0 | 0.0 | 0.0 | 0.0 | 0.0 |
| Pressure losses in tubes (kPa) | 24.39 | 21.71 | 69.6 | 52.0 | 78.3 | 50.4 |
| Electrical power supply | 1ph / 230 V / 50 Hz - 3ph / 400 V / 50 Hz | | | 3ph / 400 V / 50 Hz | | |
| Electrical power (W) | 840 | 840 | 840 | 1680 | 1680 | 2520 |
| Fan type | EC | EC | EC | EC | EC | EC |
| Maximum fan rotation speed (rpm) | 700 | 700 | 700 | 700 | 700 | 700 |
| Sound pressure (10 m) (dBA) | 42 | 42 | 42 | 44 | 45 | 47 |
| Tubes | Cobre | | | | | |
| Fins | Aluminio | | | | | |
| Air flow | Horizontal | | | Vertical, V configuration | | |
| Surface (m ²) | 49.12 | 107.61 | 643.3 | 541.4 | 983.3 | 1930.0 |
| Fans number | 1 | 1 | 1 | 2 | 2 | 3 |
| Fans diameter (mm) | 800 | 800 | 800 | 800 | 800 | 800 |
| Fins separation (mm) | 3,2 | 2,8 | 2.1 | 3.2 | 2.1 | 2.1 |
| Inlet connection | 1 1/2" | | 3" | 3" | 3" | 3" |
| Outlet connection | 1 1/2" | | 3" | 3" | 3" | 3" |
| Weight (kg) | 310 | 320 | 705 | 840 | 995 | 1775 |
| Dimensions (length x height x width) (mm) | 1425 x 1335 x 1200 | 1925 x 1335 x 1200 | 2100x1920 x1410 | 2500x1920 x1410 | 3100x1920 x1410 | 5300x1920 x1410 |



CLAUSIUS INTERNET CONNECTION & CONNECTION TO PHOTOVOLTAIC SYSTEMS

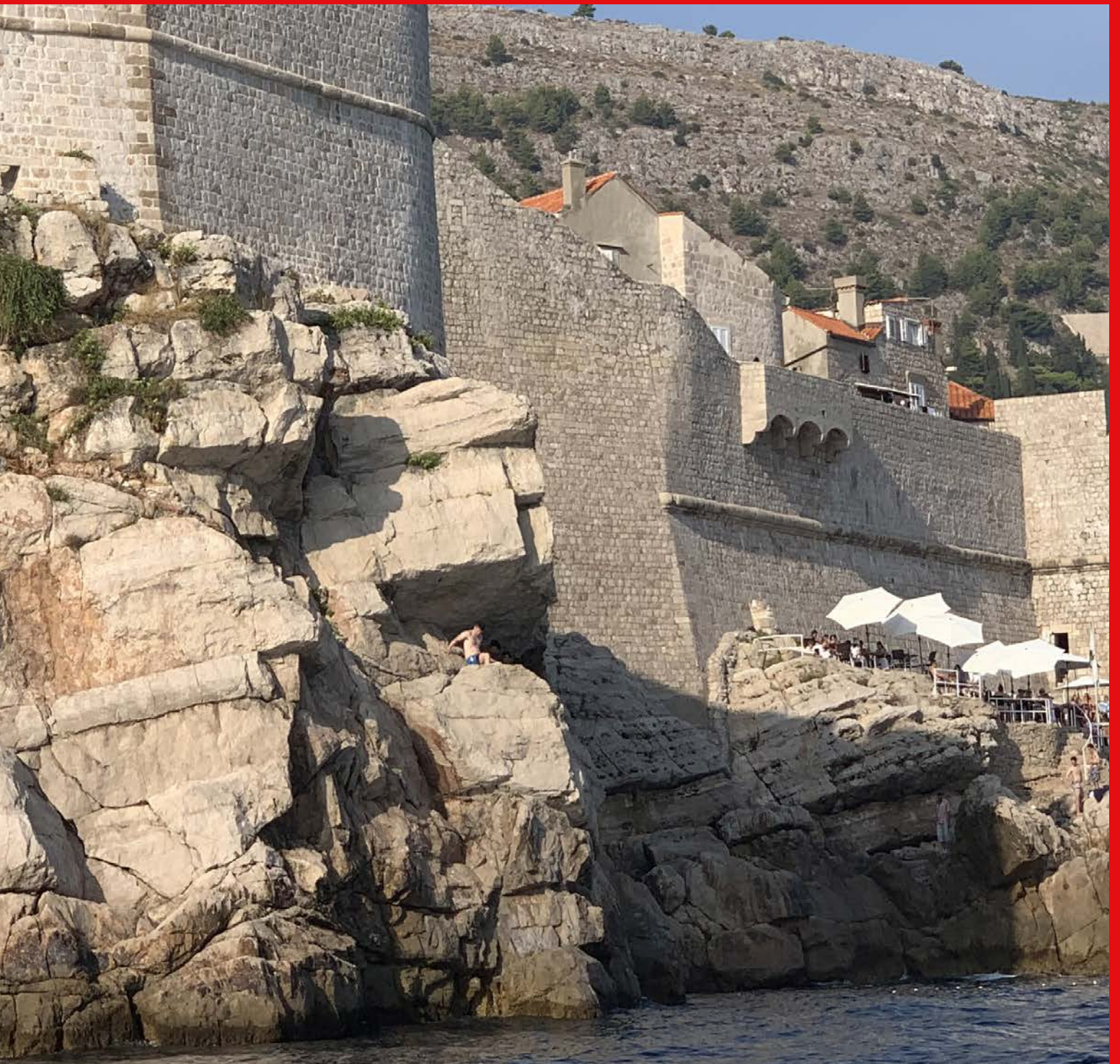

NEW CLAUSIUS INTERNET CONNECTION SYSTEM

All CLAUSIUS heat pumps can be connected to the Internet, providing immediate remote access to their status, operating conditions, efficiency values, alarm display, configuration settings, and on/off control from any mobile phone, tablet, or computer.

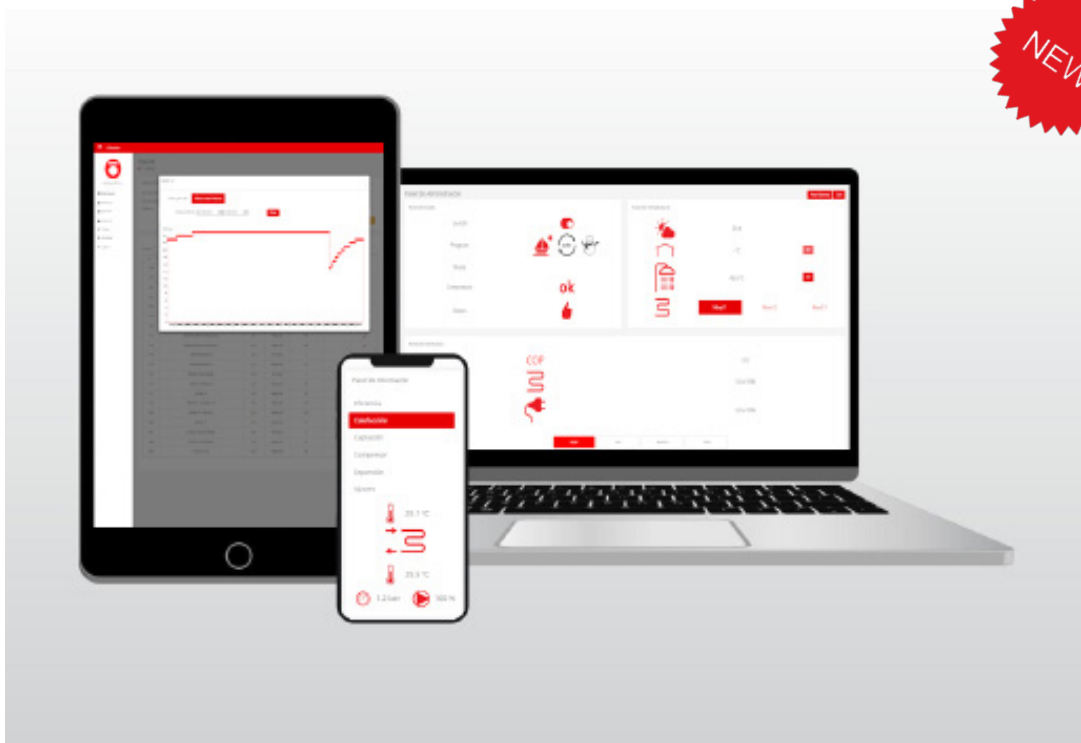

This new and enhanced internet connectivity system, specifically developed by CLAUSIUS, is based on the integration of an embedded router within the heat pump. This solution enables internet access via a wired connection, independently of the customer's local router type. The use of a wired connection ensures simple installation with no configuration required, while avoiding the connectivity issues commonly associated with Wi-Fi-based systems.

Access to the heat pump is available through any standard web browser via <http://global.clausius.es>, without requiring the installation of dedicated software or mobile applications. Through this interface, users can access all configuration and operating parameters of the heat pump.

The CLAUSIUS internet connection also allows real-time access to all user menu variables, as well as the visualisation, graphing, and downloading of historical operating data.

This remote connectivity is a powerful tool for monitoring system performance, detecting anomalies, and defining corrective actions, often without the need for physical access to the unit, thereby improving service efficiency and system reliability.

CLAUSIUS CONNECTION TO PHOTOVOLTAIC

CLAUSIUS heat pumps can be integrated with photovoltaic installations, allowing them to adjust their operating conditions based on the photovoltaic energy available at any given time. They also account for electricity rates by time-of-use, with the ultimate goal of minimizing operating costs.

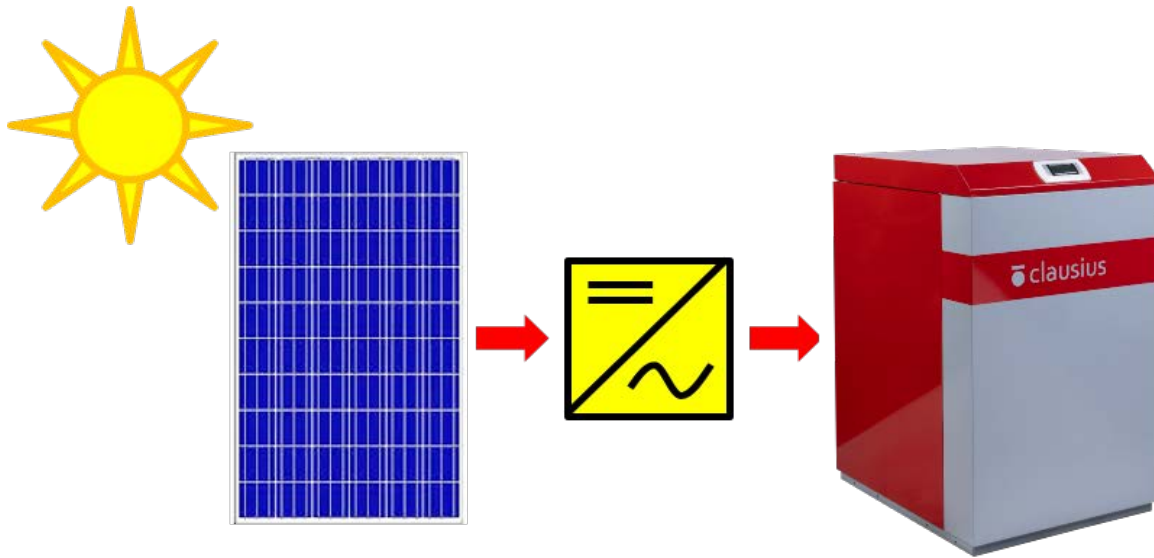

Connection to photovoltaic systems

A network analyser is used to evaluate the surplus photovoltaic energy. The heat pump communicates with the network analyser to obtain the surplus energy value and, based on the excess available, adjusts its set points and modulates its capacity to maintain the system at maximum efficiency.

The network analyzer provides all the necessary information for an efficient energy management. It includes a touchscreen for easy access to the available data and integrated ModBus communication, so it does not need an external connection. The heat pump is preconfigured for the installation of the network analyzer, ensuring a straightforward setup process.





ModBus RS485 Network Analyzer

The information on the different time slots and the corresponding electricity rates is entered into the heat pump configuration, which makes it possible to give priority to its operation in those time slots with lower rates.

Taking into account the available solar photovoltaic energy and the rate of each time slot, the heat pump can adjust its operating conditions by modifying the setpoints for domestic hot water (DHW) production, buffer or heating water temperatures. It can also adjust the maximum revolution limits in DHW, heating, and cooling modes. This optimization aims to store surplus solar energy as thermal energy and minimize operating costs at all times.



CLAUSIUS ACCESSORIES



CLAUSIUS Accesories



Internet connection kit



ModBus RS485 energy analyzer



Flow meter Allengra
DN20 (1"), DN40 (2"), DN50 (2 1/2")



Acoustic insulation for compressors



Acoustic and Anti-Vibration Base
(Classic, Elite, Strong, and Strong)



Clausius advance control



BMS (Modbus communication card)



Th-Tune control thermostat, Modbus communication
(BMS not included)



RF / WIFI Control Thermostat

CLAUSIUS Accesories



Cascade Box



Hybrid Box



1500 W or 2000 W electric heater with thermostat for DHW tanks



Additional NTC temperature sensor



DPUT Temperature sensor



3 Way Valve (1^{1/2}", 2", 3")



Paddle flow switch



Replacement of standard circulation pump (11 mwc) by the same model with 15 mwc. (For domestic models)



Software simulator

DHW and buffer tanks

DHW tanks for CLAUSIUS ground source heat pumps

CLAUSIUS DHW tanks have been sized by CLAUSIUS together with the manufacturer. All the tanks are made of AISI 316 stainless steel. Their maximum working pressure and temperature are 8 bar and 90 °C, respectively. It is worth noting the exchange surface of the coil. It is not recommended the use of tanks with coil exchange surfaces smaller than the values given in the following table.

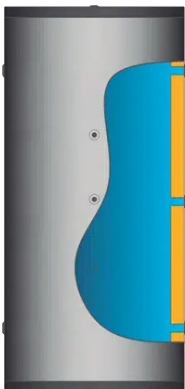

| MODEL | Capacity (liters) | Ø External (mm) | Height (mm) | Exchange surface (m ²) |
|--------------------|-------------------|-----------------|-------------|------------------------------------|
| Clausius DHW 200 | 200 | 580 | 1280 | 2,55 |
| Clausius DHW 300 | 300 | 580 | 1780 | 3,35 |
| Clausius DHW 500 | 500 | 800 | 1710 | 4,71 |
| Clausius DHW 750* | 750 | 800 | 1920 | 7 |
| Clausius DHW 1000* | 1000 | 930 | 1985 | 9 |

*With manhole.

Buffer tanks for CLAUSIUS ground source heat pumps

CLAUSIUS buffer tanks are made of carbon steel. Its maximum working pressure is 9 bar and its operation temperatures range from -5 °C to 90 °C.



| MODEL | Capacity (liters) | Ø External (mm) | Height (mm) | Weight (kg) |
|----------------------|-------------------|-----------------|-------------|-------------|
| Clausius BUFFER 100 | 100 | 480 | 850 | 45 |
| Clausius BUFFER 200 | 200 | 520 | 1503 | 69 |
| Clausius BUFFER 300 | 300 | 560 | 1863 | 106 |
| Clausius BUFFER 500 | 500 | 670 | 1921 | 128 |
| Clausius BUFFER 750 | 750* | 930 | 1828 | 171 |
| Clausius BUFFER 1000 | 1000* | 930 | 2078 | 212 |
| Clausius BUFFER 2000 | 2000* | 1280 | 2361 | 364 |

*With manhole.

Circulation pumps

Circulation pumps for Domestic ground source heat



| MODEL | |
|------------------------------|--|
| Wilo PARA 25-180/9-87/IPWM | Threaded connection, DN 1 ½" L between connections = 180 mm 1~230 V, 50/60 Hz IPWM Integrated control |
| Wilo PARA MAXO 25-180-11-F21 | Threaded connection, DN 1 ½" L between connections = 180 mm 1~230 V, 50/60 Hz IPWM Integrated control |
| Wilo PARA MAXO 25-180-15-F21 | Threaded connection, DN 1 ½" L between connections = 180 mm 1~230 V, 50/60 Hz IPWM Integrated control |

Circulation pumps for High Power ground source heat pumps



| MODEL | |
|-----------------------------|---|
| Wilo Stratos MAXO 40/0,5-12 | Flanged connection, DN 40 L between connections = 250 mm 1~230 V, 50/60 Hz 12 w.c.m |
| Wilo Stratos MAXO 40/0,5-16 | Flanged connection, DN 40 L between connections = 250 mm 1~230 V, 50/60 Hz 16 w.c.m |
| Wilo Stratos MAXO 50/0,5-12 | Threaded connection, DN 50 L between connections = 280 mm 1~230 V, 50/60 Hz 12 w.c.m |
| Wilo Stratos MAXO 50/0,5-16 | Threaded connection, DN 50 L between connections = 340 mm 1~230 V, 50/60 Hz 16 w.c.m |



CLAUSIUS GROUND SOURCE HEAT PUMP INSTALLATIONS



GROUND SOURCE HEAT PUMPS INSTALLATIONS

Geothermal energy is the thermal energy available in the ground that can be extracted as heat. If the temperature level of this energy is less than 30 °C, Ground Source Heat Pumps (GSHPs) can be used to extract ground heat for space heating and domestic hot water (DHW) production. Moreover, GSHPs can also be used for active and passive cooling. The geothermal energy is renewable, as recognised explicitly by the EU Directive 2009/28/EC.

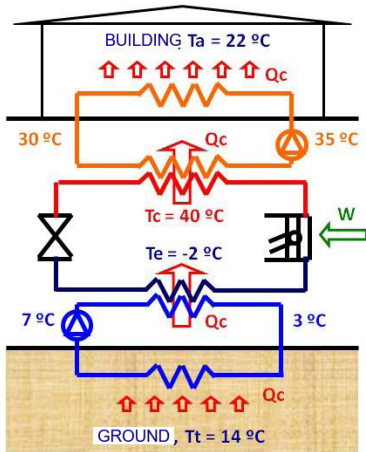

Heating

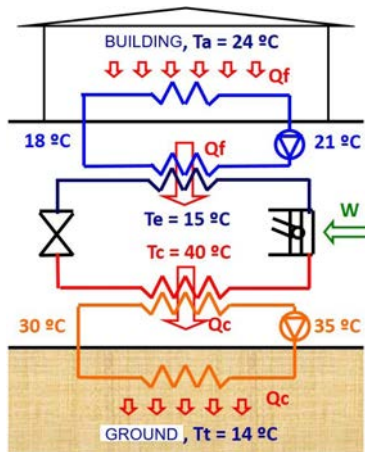

Active cooling

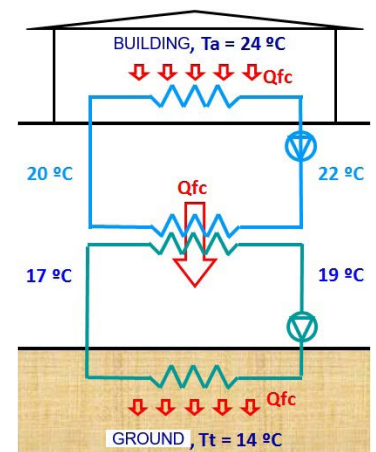

Passive cooling

The use of geothermal energy through GSHPs requires the use of collector systems to extract heat from the ground. Commonly used collecting systems are vertical boreholes, horizontal ground collectors and groundwater systems.

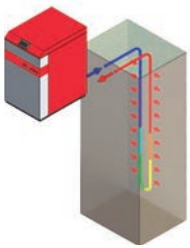

Borehole

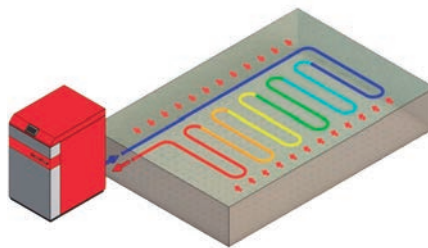

Horizontal ground collector

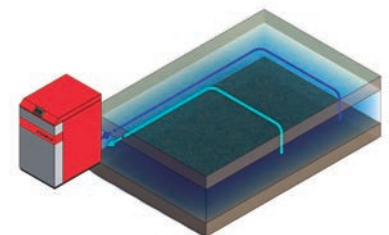

Ground water collector

Heating and cooling installations with GSHPs consist of the ground heat collector system, the heat pump itself and the heat distribution system inside the building. Commonly used distribution systems are under-floor heating and radiant surfaces, fan coil units and low temperature radiators.

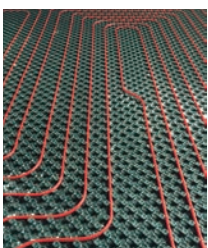

Underfloor heating



Fan-coil



Low temperature radiator

CLAUSIUS GROUND SOURCE HEAT PUMPS INSTALLATIONS



CLAUSIUS Classic without buffer



CLAUSIUS Classic with DHW tank & desuperheater



CLAUSIUS Classic cascading



Clausius HT high temperature



CLAUSIUS Strong Double cascade, 600



CLAUSIUS Elite



CLAUSIUS Classic cascade



CLAUSIUS Strong Double with DHW and buffer tank



CLAUSIUS Strong Double cascade 750 kW



CLAUSIUS Classic cascading



CLAUSIUS 4 Strong Double cascade



CLAUSIUS Hybrid system



Polígono Industrial PP Sur - PPI 5
Naves 8 y 9
36475 Porriño (Pontevedra)
España

Edificio Fundación
Campus Universitario
36310 Vigo (Pontevedra)
España

Phone: +34 886 113 611

info@ceo2green.com
info@clausius.es
www.clausius.es